

# Tutorial Letter 202/2/2016

## The Anthropological Study of Culture in a Multicultural Context

**APY1501**

**Semester 2**

**Department of Anthropology and Archaeology**

**IMPORTANT INFORMATION**

This tutorial letter contains the comments on Assignment 02 and important information about the examination.

BARCODE

## CONTENTS

		<i>Page</i>
<b>1.</b>	<b>COMMENTS ON ASSIGNMENT 02</b> .....	<b>3</b>
<b>2.</b>	<b>GENERAL MATTERS REGARDING THE EXAMINATION</b> .....	<b>6</b>
2.1	Tutorial letters not received.....	6
2.2	Admission to the examination .....	6
2.3	Delimitation for the examination .....	7
2.4	The examination paper .....	7
2.5	Examples and answers of examination questions .....	7
2.6	Assignment questions in the examination .....	15
2.7	Revision before the examination .....	15
2.8	Indigenous terms .....	19
2.9	A summary of aspects of Learning theme 9 (as example of your examination preparation) .....	19

Dear Student

This tutorial letter includes comments on Assignment 02 and general matters regarding the examination.

## 1. COMMENTS ON ASSIGNMENT 02

In this assignment we tested your knowledge of and insight into concepts relating to culture, identity, ethnicity, kinship and religion. Study the comments on the questions and options thoroughly: not only will this exercise supplement and expand your theoretical and ethnographic knowledge of the work to which the comments relate, but it will help you with your revision for the coming examination. Note that all **SG-references** in this tutorial letter refer to the Only Study Guide for APY1501.

### QUESTION 1

**Option 3 is correct.** Consult SG:69 in this regard. Option 1 is incorrect. Tools are associated with both humans and primates (see SG:43). Options 2 and 4 are incorrect because many animals display learnt behaviour in the sense that they exhibit shared behaviours. Consult SG:68 in this regard.

### QUESTION 2

From a study of the tutorial matter on the integration of culture, as illustrated by the Swazi harvest feast (see SG:72 in this regard), it is clear that **Option 4 is correct.** The political system of the Swazi with the office of the King as cultural focal point forms the basis in the *incwala* for the integration with the other aspects of their culture.

### QUESTION 3

In this question you first had to decide whether Items a, b, c and d regarding anthropology and gender are correct or incorrect, and then you had to choose the correct combination in the options. Items a and d are correct. Consult SG:83-4 in this regard. **Option 2, which includes Items a and d, is therefore correct.** Item b is incorrect. In most Western communities gender is composed by genital anatomy, but in communities where gender categories are more fluid, by inclination and behaviour. Further, the anthropological perspective distinguishes between sexed bodies and socially constructed genders. Item c is incorrect. Gender has both individual and collective dimensions. Because anthropology is inclined to focus on collectivities, the important dimension of how social or group representations of gender influence subjective constructions and then, in turn, how subjective / individual representation or self-representation of gender influences its social construction, consequently deserve closer attention.

### QUESTION 4

In this question you first had to decide whether Items a, b, c and d regarding the expression of ethnic identities are correct or incorrect, and then you had to choose the correct combination in the options. Items a, b, c and d are correct. Consult SG:69, 84 and 86 in this regard. **Option 3 which includes Items a, b, c, and d is therefore correct.**

### QUESTION 5

Members of a patrilineal descent group (eg a clan and a lineage) trace their descent through the males of each generation only. EGO will therefore trace his descent through his Fa (18), FaFa (10), FaFaFa (1) in the diagram. In each generation, sons as well as daughters (since they are his blood relatives) all belong to the descent group of their father. However, note that **only males pass on membership of the descent group to their children.** The children of female members belong to the descent group of their own fathers. See SG:102 in this regard.

When the definition above is applied to the various options, it is clear that only **Option 1 is correct**. EGO, EGO's FaFa (10) and EGO's FaBrDa (22) belong to the same patrilineal descent group. Note that 22 traces her descent through her father (17), her FaFa (10) and her FaFaFa (1), who are all males. However, her children will belong to her husband's descent group because descent in a patrilineal system is not traced through females.

The other options are all incorrect. 13 (Option 5) and 14 (Options 2, 3 and 4) are related to EGO through 6, a female, and 5 (Options 3 and 4) and 7 (Option 3) are related to EGO by marriage (the husbands of 6 and 8).

### QUESTION 6

**Cross-cousins** are the children of siblings of the opposite sex, that is, children of a brother and sister. In contrast to this, **parallel-cousins** are the children of siblings of the same sex (see SG:118).

**Option 4 is correct**. 23 and 44 are cross-cousins because 23's mother (36) is the sister of 44's father (37) and, therefore, **siblings of the opposite sex**.

Options 1, 2 and 3 are all incorrect because 14 and 15; 20, 21 and 22; as well as 22 and 23 are parallel-cousins, that is, either the children of two sisters (14 and 15, as well as 20, 21 and 22) or the children of two brothers (17 and 18).

### QUESTION 7

**Option 3 is correct** because 22 and 24 are the children of two brothers (17 and 18), that is two siblings of the same sex, and therefore meet the requirements for parallel-cousins.

Option 1 is incorrect because in a parallel descent system, males trace their descent through their fathers and females through their mothers. Therefore, in the case in question, EGO should trace his descent through his father (18) and not through his mother (36) to his MoMo (27). On the basis of this definition, EGO's sister (24) can in fact trace her descent in a parallel descent system through her Mo (36) and MoMo (27).

Option 2 is incorrect. 34 and 35 are sisters and are actually matrilineally related. However, 33, to whom they are both married, is their husband and therefore related to them through marriage and not matrilineally.

Option 4 is also incorrect because the relationship between 20 and 5 is that of grandson (20) and grandfather (5). They are therefore descendants or blood relatives and not affinal relatives.

### QUESTION 8

Answering this question required a close study of SG:119. **Option 4 is correct** because 33 is married to two **sisters** (34 and 35), a practice which in anthropology is known as sororal polygyny.

Option 1 is incorrect because 28 is married to two non-related women (27 and 29). He is therefore not practising sororal polygyny, but ordinary polygyny.

Option 2 does **not** represent an example of heterogeneous polyandry (i.e. where a woman is married to two unrelated men) and is therefore incorrect. 32 is married to two **brothers** (30 and 31) which constitutes a fraternal polyandrous relationship. Option 3 is therefore also incorrect because 41 is married to two unrelated men (39 and 40).

**QUESTION 9**

**Option 2 is correct.** Consult SG:102 in this regard. Option 1 is incorrect. A Xhosa-speaker may **not** marry someone belonging to the clans of any one of his four grandparents (SG:117). Option 3 is incorrect. It is true that a man cannot pass on membership of the matriclan to which he belongs, **but** he retains his membership of the matriclan after marriage. Option 4 is incorrect. Xhosa society is patrilineal and therefore, among Xhosa-speakers, children born from a marriage only inherit the clan name of their father.

**QUESTION 10**

In the question you were required to identify the option that did not reflect the contractual factors of marriage between members of **Southern** African indigenous societies. Transfer of a dowry from the bride's family to the bride herself (Option 1) does not form part of marriage among members of **Southern** African indigenous societies, and therefore **Option 1 was the correct option.** Consult SG:122-3 in this regard.

**QUESTION 11**

From a close reading of the section on myths it will be clear that **Option 3 is correct** and that Options 1, 2 and 4 are incorrect. Consult SG:143-4 in this regard.

**QUESTION 12**

A ritual, in terms of our definition, is an action or a series of actions, performed with dignity and solemnity, which is directly related to belief in the supernatural (see SG:148). Options 1 (a civil marriage in court) and 2 (a graduation ceremony at Unisa), therefore, cannot be correct. Although both series of actions are performed in a serious and formal way, they are not related to belief in the supernatural and are better described as ceremonies. **Option 3** (a Christian baptism in a church), in contrast, is directly related to belief in the supernatural and **is therefore correct.** Options 4 and 5 are obviously incorrect because the combinations in the respective options include incorrect options. Option 4 includes the incorrect Option 2, whereas Option 5 includes the incorrect Options 1 and 2.

**QUESTION 13**

**Option 1 is correct.** Ancestral spirits are sometimes thought to reveal themselves by **possessing people.** This is especially the case among the Venda-, North-Sotho- and Tsonga-speaking peoples of Limpopo and Mpumalanga Provinces and, to a lesser extent, among certain Tswana speakers of North-West Province. A person who is possessed is used by an ancestral spirit, known as a *lelopo* (plural *malopo*) spirit, as a **medium** to communicate with the living. People who are possessed by *malopo* spirits form a cult group which performs acts under the guidance of a *malopo* traditional doctor. When a person, usually a woman, is possessed by a *lelopo* spirit, she gets the so-called *malopo* illness, which is treated under the guidance of a *malopo* traditional doctor. The treatment of the medium is accompanied by the performance of **malopo dances** and a **purification ritual**, during which the medium is incorporated into the ranks of the *malopo* cult group.

During the *malopo* dances a great deal of liquor is consumed, and other narcotics and hallucinogenic drugs are taken in the midst of hypnotic and frequently deafening music and drum rhythms. In the process, the *malopo* medium(s) and members of the cult group go into a **trance.** The use of familiars (Option 2), fetishism (Option 3), and mana (Option 4), however, are not characteristic of the *malopo* cult. From this it is evident that Options 2, 3 and 4 are incorrect. Consult SG:146 and 152-154 for full particulars of *malopo* possession among certain indigenous groups in Southern Africa.

**QUESTION 14**

**Option 4 is correct.** Consult SG:151 in this regard. Option 1 is incorrect. Diviners provide knowledge of the supernatural, but whereas prophets (Option 4) rely for their knowledge upon their personal relationship with the supernatural, diviners use standardized procedures to interpret evidence found in various signs. Option 2 is incorrect. In establishing and maintaining communication between people and the supernatural, priests mainly speak and act on behalf of the people. Option 3 is incorrect. Medicine-men (traditional healers) specialise in healing and do not announce the will and intentions of the supernatural.

**QUESTION 15**

**Option 3 is correct.** Polytheism is the belief in a number of Gods. Hinduism provides a contemporary example thereof (see SG:138), and in the Tantra traditions of Hinduism, millions of deities are recognised (Lawrence 2012:78-9). Christianity (Option 1), Islam (Option 2) and Judaism (Option 4) are religious systems that are characterised by the belief in one god (monotheism) and therefore these options are incorrect. Consult SG:138 in this regard.

**LITERATURE CITED**

Lawrence, D.P. 2013. Hindu theism, in Taliaferro, C., Harrison, V.S. & Goetz, S. (eds.) *The Routledge Companion to Theism*. New York: Routledge, pp. 78-79.

## 2. GENERAL MATTERS REGARDING THE EXAMINATION

Before we pay attention to matters relating to the examination, we wish to thank you for the feed-back we received on the tuition methods we employ and on the course in general. We trust that your encounter with anthropology has been an enriching experience, and that you have acquired insight into human beings in general and their lives in various forms of society which will have an enduring significance for you in future.

**2.1 Tutorial letters not received**

For various reasons some students did not receive all the tutorial letters. We advise you to check the list of tutorial letters given below to make sure that you are in possession of all of them. You will need these tutorial letters when revising the assignments in preparation for the examination, and it is therefore important that you have them at hand for this purpose.

APY1501	101, 201, 202 (which you are reading now)
ANTALLX	301

Should you be missing any of these tutorial letters you can **download** them from **myUnisa** or you can request these tutorial letters from the **university** by means of

- (1) an **SMS** directed to **43579**,
- (2) an **email** send to [despatch@unisa.ac.za](mailto:despatch@unisa.ac.za) or
- (3) a **fax** sent to **012 429 4150**.

**2.2 Admission to the examination**

**ALL STUDENTS WHO REGISTERED FOR APY1501 AND SUBMITTED ASSIGNMENT 01 ON TIME WILL OBTAIN ADMISSION TO THE EXAMINATION.**

## 2.3 Delimitation for the examination

The entire syllabus will be covered in the examination and **all learning themes** therefore need to be studied for the examination.

## 2.4 The examination paper

The examination paper consists of **60 multiple-choice questions** that have to be answered in **2 hours**. As a rough guide-line, you should take approximately 2 minutes to answer a question. Do not spend more time on individual questions than your time allocation allows because you may tend to rush the other questions to make up the difference and consequently not do so well. If you have time left at the end, you can go back to earlier questions. The multiple-choice questions must be answered on mark reading sheets and all questions are of equal value. Marks for the examination count a total of 60.

The questions will be similar to those set in the assignments. So, for example, there is also a genealogical diagram upon which questions on kinship are based. The questions follow more or less the same sequence as the learning themes in the SG and are grouped together according to them (eg the human species, identity, kinship etc). We also reassure you that all questions were evaluated thoroughly beforehand in order to avoid uncertainty and confusion.

### ● MULTIPLE-CHOICE QUESTIONS

Once again we refer you to the guidelines for the answering of multiple-choice questions which were given on pp.11-13 of Tutorial letter APY1501/101.

## 2.5 Examples and answers of examination questions

Below we provide examples of possible exam questions and then also the answers with comments.

### 2.5.1 Examples of examination questions

#### QUESTION 1

Anthropologists with their holistic perspective of human beings and human problems are sometimes approached to make their knowledge regarding societies and their way of life available to a variety of organisations.

To which of the following **sub-discipline(s) of anthropology** is the above-mentioned statement applicable?

1. Linguistic anthropology
2. Archaeology
3. Physical anthropology
4. Sociocultural anthropology.

**QUESTION 2**

Select the option that **CORRECTLY** completes the following statement:

When a cultural component or custom is studied and described within the context of its own culture, anthropologists refer to such an approach as

1. ethnographic.
2. holistic.
3. culturally relativistic.
4. ethnocentric.

**QUESTION 3**

Select the option that **CORRECTLY** completes the following statement:

An anthropological study that sees the people being studied as actors in their own sociocultural context, and incorporates people's own perceptions and categorisations of the world in which they are living has adopted

1. an etic approach.
2. an emic approach.
3. a reflexive approach.
4. an ethnocentric approach.

STUDY THE FOLLOWING DIAGRAM AND THEN ANSWER QUESTION 4-7.

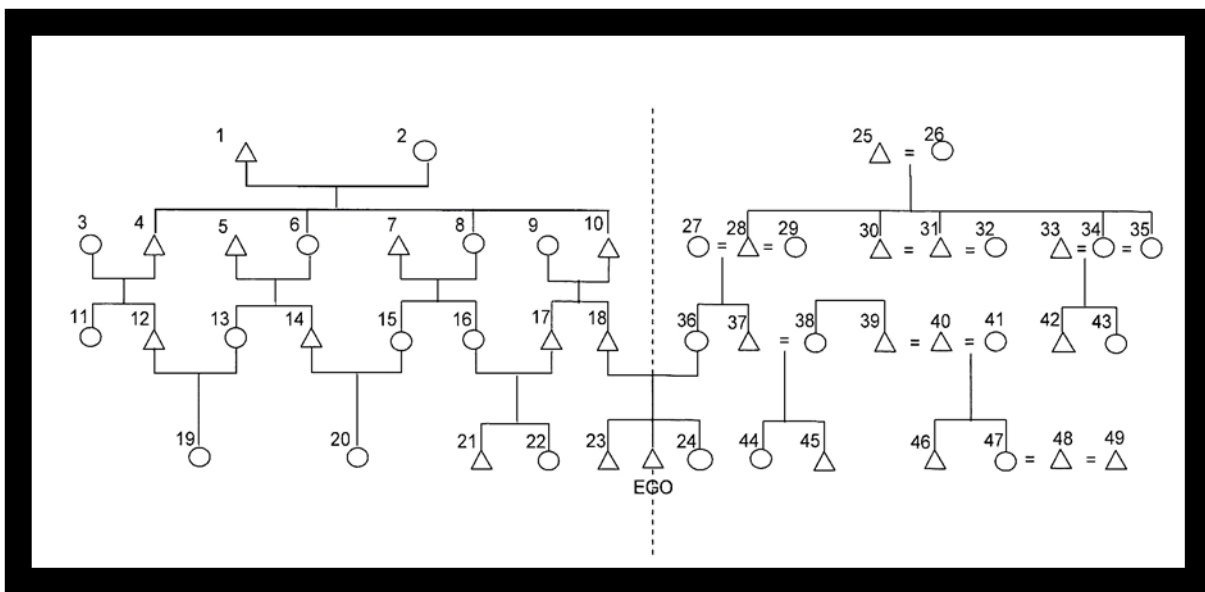

**QUESTION 4**

Who is the apical ancestor of the patrilineage to which 20 belongs?

1. 14
2. 5
3. 1
4. 6
5. 4



**QUESTION 5**

Select the option that **CORRECTLY** completes the following statement:

In a matrilineal descent system EGO would belong to the same descent group as

1. 2, 10 and 18.
2. 23, 24 and 44.
3. 27, 36 and 37.
4. 26, 28 and 35.

**QUESTION 6**

Which of the following relatives of EGO are **CORRECTLY** identified?

1. Cross-cousins: 21 and 22
2. Patrilineal kin: 19 and 22
3. Parallel-cousins: 44 and 45

**QUESTION 7**

Which of the following represents a **cross-cousin marriage**? The union between

1. 30, 31 and 32
2. 16 and 17
3. 14 and 15

**QUESTION 8**

Which one of the following is **NOT** a possible **ground for dissolution of marriage** among South African indigenous groups?

1. Marriage instability due to the mother's brother's exercising of authority over his sister's children in matrilineal societies
2. The interference of the respective kin groups in a couple's life
3. The death of the husband
4. Adultery or ill-treatment of the wife

**QUESTION 9**

Members of these descent categories cannot indicate how they are genealogically related. They assume that they are related because they share a common name. Members are forbidden to marry each other since this is regarded as incest. They do not all gather and meet for a specific purpose.

To which descent category among the Xhosa does this description apply?

1. Lineages
2. Moieties
3. Phratries
4. Clans

**QUESTION 10**

Select the option that **CORRECTLY** completes the following statement:

Initiation and incorporation into the ranks of the **Malopo cult group** are accompanied by

1. trance.
2. possession.
3. mediumship.
4. 1, 2 and 3
5. 1 and 2

**QUESTION 11**

Indicate the **INCORRECT** option:

Persons acting as leaders in societal rituals include

1. prophets.
2. priests.
3. diviners.
4. witches.
5. shamans.

**QUESTION 12**

Select the option that **CORRECTLY** completes the following statement:

Anthropologists study **religion** in order to

1. rank religions according to a developmental scale from inferiority to superiority.
2. obtain factual knowledge of the supernatural.
3. distinguish between false and true religions.
4. understand a religious system in terms of its meaning for its followers

**QUESTION 13**

Which one of the following statements **CORRECTLY** describes a **talisman**?

1. It is believed to become the temporary abode of supernatural powers or spirits since it contains various ingredients, which induce spirits or powers to dwell within it, and is used as protection against witchcraft or for securing success in war.
2. It may be worn on the body or placed in various positions where its influence is needed; it is used for protection against misfortune as well as for securing strength, health and good fortune.
3. It refers to an impersonal power, is associated with certain people and objects, it may be used for good or evil purposes, but people must know how to employ it otherwise it can be harmful to them.

**QUESTION 14**

Select the option that **CORRECTLY** completes the following statement:

**Religion** as distinguished from magic is associated with

1. an impersonal power and an attitude of dependence.
2. personalised spiritual beings and an attitude of manipulation.
3. an impersonal power and an attitude of manipulation.
4. personalised spiritual beings and an attitude of dependence.

## 2.5.2 Answers to and comments on the questions

### QUESTION 1

Nowadays anthropological knowledge is used to alleviate human suffering and solve human problems on virtually every terrain. One therefore finds that anthropological knowledge is applied in the spheres of all four sub-disciplines.

A close examination of the relevant study material (SG:6-8) reveals that, of the four sub-disciplines of anthropology, only sociocultural anthropologists study people in societal and cultural context and make their knowledge available to organisations (SG:8-10). Note on pp.9-10 the long list of areas in which anthropological knowledge is nowadays indispensable and in demand. **Option 4 is therefore the correct answer.**

Option 1 is incorrect because linguistic anthropologists are put to work exclusively where societies experience communication problems. An example is the communication problems between medical personnel and their patients in the Third World. Linguistic knowledge is also a key that offers access to the worldview of people.

Option 2 is incorrect because archaeologists are mainly involved in excavating and interpreting concrete cultural objects of prehistoric people which are then displayed in museums. Archaeological knowledge is therefore important for the conservation of cultural heritage.

Option 3 is incorrect because physical anthropologists study the physical-biological aspects and characteristics of human populations and do not study their way of life. For example, when victims of crimes and road accidents need to be identified, physical anthropologists can determine the race, gender and age of such victims from their skeletal remains.

### QUESTION 2

**The correct answer is Option 3**, because the concept of cultural relativism implies that the culture of a society should be interpreted in terms of **their** traditions and experiences (consult SG:26). What is acceptable for one society is not necessarily acceptable or “correct” for members of other societies. Many westerners regard Hindu taboos regarding the eating of beef as ridiculous and wasteful, because it is an excellent source of protein. By contrast, Hindus consider the slaughter and consumption of cattle to be barbaric. It is theorised that one of the most important reasons for the taboo regarding eating beef is that in a developing country like India, cattle manure is used for the cultivation of grain, as well as for fuel. In terms of this view, the taboo developed to ensure that there would always be sufficient manure available for fuel and fertiliser.

Options 1 and 2 are incorrect because the term ethnography that has been developed by anthropologists refers to the scientific description of people and cultures. The term holistic refers to a comprehensive view and study of culture. It implies that everything relating to the life of a society is studied, namely, the environment to which they must adapt for their survival, their history, kinship system, economy, political and religious systems, to mention only a few aspects. A holistic view of culture also implies that the integration of the different aspects of such a culture are studied to determine the influence of, say, religion on the other aspects thereof (consult SG:4 and 34 respectively).

Option 4 is incorrect because the concept ethnocentric implies that one evaluates the customs and behaviour of other people subjectively in terms of one's own cultural values. This approach is therefore the opposite of cultural relativism (consult SG:25-26).

### QUESTION 3

**Option 2 is correct.** Consult SG: 25 in this regard. Option 1 is incorrect. In the case of an etic approach, an anthropologist works from the assumption that people are so subjectively involved in their own life-styles that they find it difficult to have an impartial view of it and therefore studies the culture of a society from the outside as a scientist. However, the anthropologist, like all scientists, is also human and possesses preferences and predispositions that make unqualified objectivity impossible. This is why anthropologists combine the **etic** and **emic** approaches in their fieldwork strategies (see SG: 25).

Option 3 is incorrect (see SG: 28). Reflexivity implies more than an emic approach and requires a " sensitive, intensive and continual involvement of the fieldworker with the people being studied, as well as an identification with, and a moral responsibility for their problems and quality of life" (De Jongh 2010:297-298 cited on SG: 28).

Option 4 is incorrect. Ethnocentrism is the inclination of many people to regard their own culture or way of life as superior, and they use the values and practices of their own culture to judge the behaviour and beliefs of others (see SG 26).

### QUESTION 4

Before answering this question and the next one, you should have thoroughly studied the various systems of descent reckoning (SG:100-107), especially patrilineal and matrilineal systems.

From an analysis of the diagram it should have been clear that the apical ancestor of 20 is traced through 14 to 5. **Option 2 is therefore the correct answer.** The apical ancestor of 20 is therefore 5 and not 1.

Note that the apical ancestor of 20 in a patrilineal system cannot be 1, because in such a system one traces one's descent through males only. Patrilineal descent can therefore never be traced through a female - in this case 6 in the diagram.

### QUESTION 5

In a matrilineal descent system EGO traces his descent through females. Both males and females are, however, members of a matrilineal descent group although only the daughter passes membership of their mother's descent group to their children.

Since EGO traces his descent through his mother (36) to 27, his earliest ancestress, and the latter's son (37) also belongs to her matrilineage, **Option 3 is correct.**

Option 1 is incorrect because it refers to Ego's patrilineal kin.

Option 2 is incorrect because 23 and 24 are his own brother and sister and therefore belong to his matrilineage, while 44 is incorrect because she traces her descent in a matrilineal descent system through a female (38) that belongs to a different descent group to EGO. Note that 38 is not genealogically related to EGO's matrilineage by descent.

### QUESTION 6

Option 1 is incorrect because 21 and 22 are parallel-cousins of EGO.

**Option 2 is correct** because 19 and 22 are patrilineal kin of EGO. Note that they trace their descent through males only.

Option 3 is also incorrect because 44 and 45 are cross-cousins of EGO.

### QUESTION 7

**Option 2 is correct.** The union between 16 and 17 represents a cross-cousin marriage. 16 and 17 are the children of siblings of the opposite sex, that is the children of a sister (8) and a brother (10) respectively.

Option 1 is incorrect. The union between 30, 31 and 32 is an example of fraternal polyandry.

Option 3 is incorrect. The union between 14 and 15 represents a parallel-cousin marriage.

### QUESTION 8

Because you were required to indicate which option is **NOT** a possible **ground for the dissolution of marriage among South African indigenous groups**, the incorrect option here is the correct answer.

Option 1 is correct. Marriages in matrilineal societies such as the Bemba of Zambia are indeed unstable and, because of the authority of a mother's brother over his sister's children, easier to dissolve than in patrilineal societies (see SG:124).

Option 2 is also correct, because marriages among South African indigenous groups are indeed sometimes dissolved due to the interference by kin (such as a mother-in-law or divorced sister-in-law who once again lives with or near her father's home).

**Option 3 is the correct answer**, because among South African indigenous groups the death of a husband is not a ground for the dissolution of a marriage. Consult SG:125 in this regard. In these societies marriage is regarded as a contract between two descent groups which places reciprocal obligations on both these groups. The woman's descent group should contribute a healthy, fertile woman with an ability to work while that of the man undertakes to protect and sustain her and to beget children with her. These obligations are not terminated by death. The **levirate** (the continuation of a deceased husband's marriage) and **sororal substitution or supplementation** (the continuation of a deceased wife's marriage, or the supplementation of the deficiency of an infertile wife, respectively) are customs among South African indigenous groups which emphasise the reciprocal obligations of the respective descent groups and ensure that the marriage is not terminated by the death of one of the marriage partners.

Option 4 is also correct. On SG:125, adultery and the ill-treatment of a wife are listed as grounds for the dissolution of marriages.

### QUESTION 9

A thorough study of 8.3.3.2 (Descent groups) in Learning Theme 8 was necessary before this question could be answered (see SG:107-113). From such a study it would have been apparent that moieties (Option 2) and phratries (Option 3) are not found among the Xhosa. Lineages (Option 1) and clans (Option 4) do, however, occur among Xhosa-speakers. If genealogical relationship cannot, however, be indicated then the descent category referred to in the option would be clans. The reference to a common name and exogamy are further indications that the contents of Option 4 refer to clans. **Option 4 is therefore correct.**

**QUESTION 10**

Ancestral spirits are sometimes thought to reveal themselves by **possessing people**. This is especially the case among the Venda-, North-Sotho- and Tsonga-speaking peoples of Limpopo and Mpumalanga Provinces and to a lesser extent among certain Tswana speakers of the North-West Province. A person who is possessed is used by an ancestral spirit, known as a *lelopo* spirit (plural *malopo*), as a **medium** to communicate with the living. People who are possessed by *malopo* spirits form a cult group, which performs acts under the guidance of a *malopo* traditional doctor.

When a person, usually a woman, is possessed by a *lelopo* spirit, she gets the so-called *malopo* illness, which is treated under the guidance of a *malopo* traditional doctor. The treatment of the medium is accompanied by the performance of *malopo* dances and a purification ritual, during which the medium is incorporated into the ranks of the *malopo* cult group. During the *malopo* dances a great deal of liquor is consumed, and other narcotics and hallucinogenic drugs are taken in the midst of hypnotic and frequently deafening music and drum rhythms. In the process, the *malopo* medium(s) and members of the cult group go into a **trance**.

From this, it is evident that **Options 1, 2 and 3** are correct. **Option 4 is therefore the correct answer**. Consult SG:146 and 152-154 for full particulars of *malopo* possession among certain indigenous groups in Southern Africa.

**QUESTION 11**

The instruction of this question required you to indicate the **incorrect option** for the correct answer.

Prophets, priests, diviners and shamans (Options 1, 2, 3 and 5) all act as leaders in the performance of rituals (consult SG:151-152) and therefore none of these options is the correct answer.

**Option 4 is the correct answer** because witches never act as leaders when rituals are performed, but, like sorcerers, are associated with the malevolent (evil) application of magic to harm people (consult SG:142 for further information on witches and their malevolent actions).

**QUESTION 12**

Option 1 is incorrect. Anthropologists generally reject unidirectional evolutionary explanations of the development of cultural aspects from inferior to superior phenomena. Options 2 and 3 are incorrect because it is not the task of the anthropologist to factually evaluate people and their religious views or to establish whether a particular religious system is 'true' or 'false'. Anthropologists merely attempt to gain a better understanding of a religion within the context of the culture of a society. Anthropologists attempt, in particular, to find out what a religious system means to its adherents (Option 4), otherwise their research results would be seen as subjective rather than objective, as is required of scientists. **Option 4 is therefore correct**.

**QUESTION 13**

**Option 2 is correct**. Consult SG:141 in this regard. Options 1 and 3 are incorrect because they describe a fetish (see SG:140-141) and the concept of mana (see SG:141-142) respectively, and not a talisman.

## QUESTION 14

**Option 4 is correct.** Personalised spiritual beings and an attitude of dependence are associated with religion. Consult SG:132-133 in this regard. Options 1, 2 and 3 are incorrect because an impersonal power and/or an attitude of manipulation is/are associated with magic.

### 2.6 Assignment questions in the examination

Do not disregard the sections of the tutorial matter that were covered in the assignments. As much as 20% of the examination paper may be taken from the assignments. We may ask identical questions to those that were set in the assignments or they may be adjusted in the examination paper. It will also be worth your while to revise the assignments when doing revision for the examination, since it will help you to understand the kind of reasoning necessary to answer these questions.

### 2.7 Revision before the examination

Hopefully you have now reached the stage where you can start with revision of the tutorial matter before the examination. The study program and the assignments have enabled you to cover the whole syllabus, and sufficient time is now left to once again work through the tutorial matter systematically in order to thoroughly prepare for the examination.

On p.9 of Tutorial letter APY1501/101 you will find a revision program that may be useful for planning your revision. Of course, you will have to make adjustments to this program, in order to meet your personal circumstances. Whatever the time schedule that you are following, we recommend the following procedures.

- **REPEATING THE ASSIGNMENTS**

You are in possession of the assignments, as well as the tutorial letter containing solutions to questions, together with explanations concerning the accuracy or inaccuracy of options. **By repeating** the assignments without consulting the solutions beforehand, you can test your readiness for the examination. **You should aim at being able to answer all questions correctly, including the reasoning in connection with incorrect options, without the aid of the tutorial matter.** Remember that although the entire examination paper is not going to be made up of assignment questions, many of the incorrect options refer to aspects of the tutorial matter that may appear in examination questions, and for this reason a thorough understanding of the topics of these options can only be to your advantage.

- **USING KEY CONCEPTS**

Make sure that you understand and can use the anthropological terms and key concepts in the SG correctly. These terms and key concepts make up the “vocabulary” of anthropology and without them you will not be able to answer the examination questions. In the study objectives of each learning theme and at the end of each learning theme, a list is provided of key concepts that appear in the particular learning theme.

Use these terms and key concepts to revise a learning theme or even a whole study unit. You can test your knowledge and understanding of these key concepts, or you can write down a few notes about each one that you can use later for quick reference. The lists of key concepts, however, also contain terms and concepts which are not important. For example, some terms from African and foreign languages are not important. However, most of the key concepts are important.

Below we provide you with **some** examples of key concepts in Learning theme 8 for purposes of revision. You should now make your own notes on key concepts in other learning themes. For this purpose we refer you to pp10-11 of Tutorial Letter APY1501/101 where you will find an example of how to make summaries for examination purposes.

### KEY CONCEPTS

KINSHIP SYSTEMS	
<b>Affinity</b>	Refers to relationships produced by marriage
<b>Alliance theory</b>	Developed where rules of exogamy prohibit marriage within the same group Strategy of seeking alliances through marriage between hostile groups Such marriage alliances may be formed between numerous neighbouring groups without restriction
<b>Apical ancestor</b>	The most senior member of the lineage, living or deceased, indicated in the diagram; in a patrilineage, a male, and in a matrilineage, a female
<b>Clans</b>	Unilineal descent groups Consist of members who claim to be descended from a common fictive ancestor. Descent can therefore not be demonstrated genealogically as in the case of lineages Mostly confined to non-western societies
<b>Clanship</b>	Clan members are identified by means of a distinctive clan name that is transferred from parent to child Note the connection between clans and lineages Ranking of clans occurs in many non-western societies Clans are not localised groups and clan members are usually spread over a wide area Clans are usually exogamous groups Clans are sometimes corporate groups - not among South African indigenous groups Connection between clanship and totemism
<b>Cognatic descent</b>	Refers to the tracing of descent through both parents, through all four grandparents, all eight great-grandparents, and so forth
<b>Consanguinity</b>	Refers to relations based on biological ties, whether they are authentic or fictive May also result from adoption
<b>Cross-cousins</b>	The term refers to the children of a brother and sister
<b>Descent</b>	Refers to someone's origin through a line of successive ancestors
<b>Diagram</b>	Here a diagram refers to a genealogy or "family tree" which shows all the different "branches" of descendants of a particular ancestor or a number of ancestors Can serve various purposes
<b>Double descent</b>	A double unilineal descent system, according to which patrilineal descent is used for certain purposes, while matrilineal descent is used for other purposes This system of descent reckoning functions among the Herero of Namibia



<b>Dual organisation</b>	<p>A society which is divided into two halves has a moiety division or dual organisation</p> <p>These halves may be two major clans, or may each include a number of clans</p> <p>The two sections may also be exogamous units</p> <p>Moiety membership may also involve particular rights and obligations</p>		
<b>EGO</b>	<p>Latin word meaning I</p> <p>It refers to the starting point for analysing a genealogy</p>		
<b>Endogamy</b>	<p>The rule that someone is expected to marry within a certain group</p> <p>Examples:</p> <p>alliance endogamy</p> <p>local group endogamy</p> <p>kin group endogamy (parallel-cousin marriage and cross-cousin marriage)</p>		
<b>Exchange of brides</b>	<p>Marriage custom where two kin groups exchange daughters</p>		
<b>Exogamy</b>	<p>A prohibition against marriage within a particular group (family, lineage or clan)</p> <p>Prohibition may be supported by supernatural sanctions</p> <p>Still widely observed among Southern Nguni</p> <p>Note: exogamy and incest are not synonymous</p>		
<b>Genealogy</b>	<p>See the term, diagram, above</p>		
<b>Generation</b>	<p>A single stage in the descent of people that comprises approximately 25-30 years</p>		
<b>Kinship</b>	<p>Refers to two types of relationships, namely descent and affinity</p>		
<b>Lineages</b>	<p>Refers to a set of people who trace their descent from a common ancestor through known links</p> <p>The relationship of every member to other lineage members is known in genealogical terms</p> <p>Also note that the term lineage refers to deceased and living members, whilst the term lineage group refers to the latter only</p> <p>Make sure that you are conversant with the connections between clans and lineages and also the differences between the two phenomena</p>		
<b>Lineal kin</b>	<p>Are consanguineal relatives in the direct line of descent</p>		
<b>Marriage</b>	<p><u>Choice of marriage partners:</u></p> <p>maturity or adulthood</p> <p>restrictions based on kinship (see exogamy above)</p> <p>prohibitions connected with ritual avoidances</p> <p>preferential marriage (cf. the term endogamy above)</p>		
	<p><u>Choice of marriage partners in secondary marriages:</u></p>		
	polygamy	polygyny	sororal polygyny
		polyandry	fraternal and heterogeneous forms
	Levirate		
	sororate	two other forms apart from the polygynous form	
Ghost marriage			

<b>Marriage goods</b>	<p>Goods transferred by the husband's kin group to that of the wife</p> <p>Transfer of marriage goods is compulsory and forms part of the marriage contract</p> <p>Nature and quantity of the goods differ from people to people</p> <p>Note that the goods delivered should not be regarded as payment for the bride</p>
<b>Matrilineal descent</b>	<p>Refers to descent reckoning through a person's mother, mother's mother, mother's mother's mother and so forth</p> <p>Characteristics:</p> <p><u>Matronomy</u> - children bear the family name of their mother</p> <p><u>Matrilineal succession</u> - a man is succeeded by his Br and then by his SiSo</p> <p><u>Matrilineal inheritance</u> - property is inherited in the mother's line</p>
<b>Nominal kin</b>	<p>All the individuals who are acknowledged as kin, for example, all one's ancestors on the father's side, as well as the mother's side in the case of a cognatic descent system</p>
<b>Parallel descent</b>	<p>According to this system males reckon descent through their fathers and females reckon it through their mothers</p> <p>The inheritance of property also follows the same principle</p>
<b>Patrilineal descent</b>	<p>Refers to descent reckoning through a person's father, father's father, father's father's father, and so on</p> <p>Characteristics:</p> <p><u>patronomy</u> - children bear the family name of their father</p> <p><u>patrilineal succession</u> - a man is succeeded by his So and then by his SoSo</p> <p><u>patrilineal inheritance</u> - property is inherited in the male line</p>
<b>Phratries</b>	<p>Refers to an association of two or more clans who claim descent from a common ancestor</p> <p>Recognition of their common origin may be reflected in the rendering of assistance and the showing of solidarity</p> <p>Phratries are not found in southern Africa and occur mainly among certain Native American tribes and in parts of western New Guinea</p>
<b>Residential arrangements</b>	<p>This refers to post-marital rules of residence</p> <p>The following are distinguished:</p> <p><u>neolocal residence</u> - the couple reside in a locality independently of the parents of either</p> <p><u>patrilocal or virilocal residence</u> - the couple reside with the husband's kin group</p> <p><u>matrilocal or uxorilocal residence</u> - the couple reside with or close to the wife's family</p> <p><u>avunculocal residence</u> - in some matrilineal societies the married couple reside with the man's maternal uncle</p> <p><u>bilocal residence</u> - the couple are expected to live for a period with or near the bride's parents and for another period with or near the groom's parents</p>
<b>Siblings</b>	<p>Refers to persons of either sex who have the same father and mother</p>
<b>Unilineal descent</b>	<p>Descent reckoning through only one parent is recognised</p> <p>Patrilineal descent (through the father and his male ancestors) and matrilineal descent (through the mother and her female ancestors) are examples of unilineal descent systems</p>
<b>Unilineal descent groups</b>	<p>See lineages, clans, phratries and moieties above for examples of these groups.</p>





## SPIRITS OF THE DEAD

There is widespread belief in life after death. What **differs** are the views about the **type of life** that exists.

Among certain indigenous societies in South Africa it is believed that every person is composed of three entities, namely

a **body**  
a **soul** (life force)  
and a **spirit**.

When someone dies, the soul and spirit leave the body and continue to exist as a **single** entity within the world of the ancestors. **Only those who are remembered by their kin**, however, are venerated as ancestor spirits. Those who had a high status when alive are seen as the most influential ancestor spirits. Ancestor spirits are found

under the ground  
in the heavens  
where the sun sets  
in sacred mountains  
in sacred objects and animals (among the Venda)  
in close proximity to descendants.

**Kin groups include living as well as deceased relatives.**

- There are also different views about the **ability of the dead to influence or communicate with the living**.

Societies who have an ancestor cult believe that

- the dead have greater powers than the living
- the dead influence the living but usually only their own kin
- the ancestors send good or bad fortune depending on their relations with their kin
- good relations with the ancestors are necessary and are maintained by rituals that usually include the killing of an animal such as an ox or goat, the pouring of beer and calling on the ancestors.

The rituals are usually performed by the living kin of the ancestor(s) being called on, or, in the case of tribal ancestors, by the chief of the tribe.

- **Christian beliefs**

Christians believe in the **immortality of the soul** but most **deny communication with the dead** and visits to graves, and erecting tombstones are regarded as tokens of loyalty and affection and not actual contact with kin.

***Note that religion is closely associated with the kinship system of most societies.***

What do we call this interrelation between various aspects of culture?

## THE SUPERNATURAL IN NATURE

There is often a **close relationship** between religious ideas and natural phenomena. Association of natural phenomena with the supernatural occurred in many of the great religious systems of the past, eg that of the Greeks, Romans, ancient Egyptians, etc and still occurs today, eg in Hinduism. There are **several ways of spiritualising** these phenomena. They may be believed to be **inhabited by spirits, eg the spirits of the dead or they may be regarded as Gods.**

### GODS

➤ **Monotheism**

Belief in the existence of one god  
(Examples of this are to be found in Christianity, Islam and Judaism.)

➤ **Polytheism**

Belief in the existence of more than one god

Zulu - *uNkulunkulu* and *Nomkhubulwana*

Ancient Greeks - Pantheon of gods

!Xū - The great god who lives in the eastern sky and the lesser god who lives in the western sky.

➤ **Atheism**

The belief that a god (or gods) does not exist.

➤ **Deism**

The creator has withdrawn from the world and is no longer involved in human affairs.

➤ **Theism**

The creator is still involved with creation, directs its affairs and has a personal relationship with it.

Deism <----->Theism

These are polar concepts and most beliefs regarding the creator fall between the two.

## TOTEMS

### ➤ What are they?

Totems are objects, animals, plants etc associated with a particular group.

The Ndebele have totemic clans. The Khumalo clan may not eat fish or rock rabbit (*dassie*) because these are their totems.

### ➤ Characteristics of totemic groups

- The group is closely connected with its totem.
- They usually occur among groups with unilineal systems of descent reckoning such as clans and lineages. An exception here is the Sotho who do not have clans but totemic groups.
- The group is frequently named after its totem which is believed to be its ancestor.

**Southern Ndebele.** The Sibanyoni clan is named after the feather (*isiba*) of the guinea-fowl (*lenyoni*). The guinea-fowl is therefore considered to be its clan ancestor.

- The totem may be closely associated with the well-being of the group concerned and so may not be eaten, killed or hurt in any way. It must be venerated and protected.

#### Exception

Among the Australian aborigines, the totem forms part of their diet and rituals are performed to ensure its increase.

**ARE YOU AWARE THAT THE XHOSA GENERALLY DO NOT HAVE TOTEMIC CLANS, NOR DO THEY VENERATE ANY TOTEMIC OBJECTS OR ANIMALS?**



## THE SUPERNATURAL IN IMAGES, WORDS AND ACTIONS

### ➤ Images

Images of gods and spirits are often believed to be the **temporary homes** of such supernatural beings. They are placed on altars in homes and temples.

Certain Hindu in Natal place a brass container filled with water on their altars at home as the temporary home of the goddess, Gange. She is named after the River Ganges.

#### Exception

Statues in Roman Catholic Churches are not believed to be the home of the person they depict.

### ➤ Fetishes

These are objects to which supernatural powers are ascribed in some societies. They also serve as temporary dwellings for supernatural beings but **unlike images, are worn on a person**. Ingredients may be put into the objects to entice the spirits to dwell in them. They are used for protection against evil or success in war.

### ➤ Charms, talismans and amulets

These objects all fall in the same category. **They are worn on a person or placed where the influence of the supernatural is needed**, for example, under a roof or in a garden. They are used for:

- protection against misfortune
- prevention of illness
- obtaining strength and good fortune.

### ➤ Spells

Spells **always involve words**. These may be sung or said. They are intended to bring about a desired result **if uttered correctly**. The word(s) may be the name of the person to be influenced or harmed. Spells may be used to make medicine more powerful.

### ➤ Simulation

This involves **actions** or **gestures** that are intended to achieve a desired goal. The actions/gestures imitate some part of what is desired.

Shaking a stick at an approaching storm by a Mpondo man is a gesture intended to frighten the storm away.

A dance to imitate the wriggling of a grub eaten by the Australian aborigines is intended by them to increase the supply of these grubs, which are an important source of food.

### Mana and ritual impurity

**Mana is an impersonal supernatural power present in people and objects.** It does not occur in equal amounts. Some bearers have more mana than others.

Mana **may be increased by ritual acts**. In itself it is a neutral power but it can be used for both good and evil. Care must be taken when contact is made with persons and objects having mana.





## ALTERED STATES OF CONSCIOUSNESS

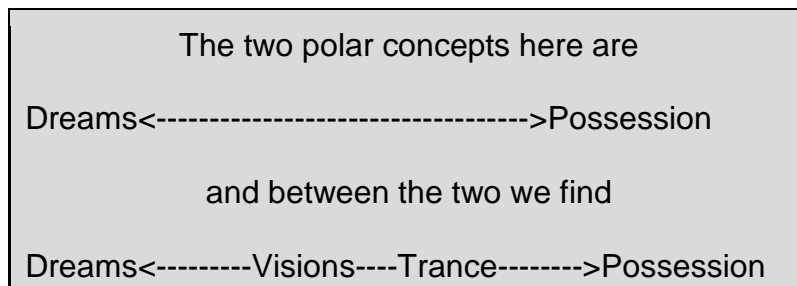

### ➤ Dreams

**Dreams only occur during sleep.** Many people regard them as sources of information about the future or the supernatural and in this sense they are a means of communication with the supernatural. Dreams must usually be interpreted. A biblical example of this is Joseph's interpretation of the dreams of the Pharaoh.

### ➤ Trance

**Trance is induced by hypnosis, drugs, alcohol etc.** During this state people hear, see or experience things which are interpreted as guidelines for the present or future.

### ➤ Visions

**Visions can occur during dreams, when in a trance or when awake.** Many religions report communications from the supernatural during visions. Visions are individual experiences, and those who experience them must convince others of their reality.

### ➤ Possession

Possession occurs when an external spirit or supernatural power inhabits a person. There are two types of possession.

- **Malevolent (Negative) possession**

This is possession by an **evil spirit** and is often manifested in the form of 'incurable illness'.

- **Benevolent (Positive) possession**

This is possession by a **benevolent** (good) spirit.

- **Mediumship**

The possessed person is **under control** of a spirit that communicates with other people through the possessed person.

- **Shamanism**

The possessed person is believed to **command and control** the spirit by which he/she is possessed.



## LEADERS IN RITUALS

### ➤ Priests

Priests act as a link between the people and the supernatural. They represent the people concerned (note that they are usually members of a descent group), as well as speak and act on behalf of the supernatural.

There are two kinds of priests.

<b>Hereditary priests</b>	<b>Priests who are formally trained</b>
eg ancestor cult	eg priests in a Christian church

### ➤ Prophets

**Prophets speak** to the people **on behalf of the supernatural**. They speak as instructed and do not act on behalf of the people.

### ➤ Diviners

Diviners **provide information from the supernatural at the request** of the people. Various procedures are used to obtain this information. Can you name some of these procedures?

Diviners inform people of the necessity to perform a ritual or to take part in it, **but do not necessarily take the lead** in the performance of such a ritual.

### ➤ Traditional healers

Traditional leaders specialise in providing medicines for:

- healing
- the treatment of other forms misfortunes
- securing success (eg in battle)
- protection against evil, and the
- fulfilment of desires (eg love potions).

**Traditional healers do not practice divination**. They have knowledge of the medicinal properties of various substances, but also ascribe the effect of their medicines to the supernatural. In this sense then their dispensing of medicines and other functions can be seen as ritual acts.

### ➤ Herbalists

Herbalists are **a particular type of medicine man** who has specialised knowledge of the medicinal properties of plants, roots etc. They also do not practice divination. Their knowledge is learned, but is seen as originally coming from the supernatural.

### ➤ Shaman

The term shaman is commonly used as a synonym for a diviner. More specifically, a shaman is **a medicine man who is also a diviner**. The term is not commonly used for a ritual leader in the South African context.

**RITUALS MAY BE PERFORMED AT REGULAR INTERVALS OR LINKED TO PARTICULAR EVENTS OR CRISES.**

➤ **Occasional rituals**

Such rituals are performed when necessary, for example:

- during family disputes
- when building a new house
- during illness, and
- thanksgiving to the ancestral spirits.

➤ **Cyclical rituals**

These rituals occur during stages in the life of the individual (eg birth, initiation, marriage, death) OR during specific seasons (eg ploughing, harvesting etc).



We wish you all the best with your studies. Please get in touch with us if you are experiencing any problems with the study material.

Kind regards

**Mr GH Maree**

012 429 6448

[mareegh@unisa.ac.za](mailto:mareegh@unisa.ac.za)

**Mrs A Grootboom**

012 429 2100

[groota@unisa.ac.za](mailto:groota@unisa.ac.za)