

AN OVERVIEW ON THE DISTRIBUTION OF AN ESTATE OF A PERSON DYING WITHOUT OR WITH A WILL



JUSTICE COLLEGE

Margaret Meyer
Masters' Training: Justice College
March 2011

access to justice for all



the doj & cd

Department:
Justice and Constitutional Development
REPUBLIC OF SOUTH AFRICA

INTESTATE AND TESTATE SUCCESSION: AN OVERVIEW

1.1 Introduction

For purposes of this note the term “succession” refers to the process whereby the heirs of a deceased person succeed to the assets which the deceased left behind at death. Heirs can only succeed to the assets of a deceased person which remain after all the estate expenses and debts which the deceased had at date of death are fully paid.

The term “estate” refers to all the assets and liabilities which a deceased person leaves behind at his or her death. If the deceased’s assets are more than his or her debts, we speak of a solvent estate, and where the deceased’s debts are more than his or her assets, we speak of an insolvent estate. In the latter instance all the assets of the deceased must be sold and the proceeds thereof must be divided among the deceased’s creditors. In an insolvent estate there are usually no assets left that can be inherited by the heirs.

The process in terms of which the deceased’s assets are collected, all debts and administration costs are paid, and the balance of the estate assets transferred to the heirs, is known as the administration of the estate. The person appointed to administer the estate of a deceased person is known either as an executor (where the value of the estate assets exceed R125 000) or a Master’s Representative (where the value of the estate assets are less than R125 000).

The heirs to an inheritance from a deceased estate are determined either in a valid will left by the deceased, or failing which, as determined in terms of the rules of intestate succession. When the heirs are determined in a valid will left by the deceased we speak of testate succession and when the heirs are determined by application of the rules of the Intestate Succession Act, 81 of 1987 it is referred to as intestate succession. Both testate succession and intestate succession will be dealt with more fully further on in this note.

1.2 What happens to a person's estate when he or she dies?

At death the estate of the deceased person is frozen, and no-one may withdraw funds from the deceased's bank accounts or deal with any of the estate assets without the necessary permission from the Master of the High Court. If the deceased was married in community of property, the joint estate is frozen. This situation often creates hardship for the surviving spouse, especially where the bank accounts were all in the name of the joint estate or in the name of the deceased.

1.3 Reporting of the estate to the Master of the High Court

In terms of the Administration of Estates Act, 66 of 1965, if a person dies in the Republic and leaves any assets **or** a will (or both), then his or her estate must be reported to the Master of the High Court within 14 days after his or her death. The duty to report the estate rests on the surviving spouse (if any), alternatively on the nearest relative or connection who resides in the area where the death occurred. If there is no such relative or connection to report the estate, then the duty rests on the person who immediately after the death has control of the premises at which the death occurred.

In practice it often happens that where the deceased nominated a bank, trust company or an attorney as executor in a will, that the family usually reports the death of the deceased to the nominated executor, who in turn then reports the estate to the Master of the High Court on behalf of the family.

When reporting an estate to the Master there are a number of prescribed forms and documents which must be lodged in the reporting process.

The deceased's ordinarily place of residence, and not the place where he or she died, determines which Master has jurisdiction and consequently where the estate must be reported. It is the Master in the area of jurisdiction where the deceased person normally resided to whom the estate must be reported.

If the value of the estate is less than R50 000 and the deceased did not leave a will, then the estate can also be reported at a Service Point of the Master. Every Magistrate has been designated as a Service Point, and therefore the Service Point in the area where the deceased was resident could possibly have jurisdiction in the estate.

Although an estate can be reported at a Service Point, it should be noted that all estates are administered and distributed under the supervision and control of the Master of the High Court.

1.4 Appointment of an executor or Master's Representative

No-one may administer or distribute the estate of a deceased person except under letters of executorship or letters of authority granted to him or her by the Master of the High Court. In terms of the Administration of Estates Act it is an offence for any person to administer and distribute an estate without the necessary authorization, and if charged with such an offence and found guilty, the perpetrator could be given a fine or be sentenced to serve a period in prison.

The value of the estate will determine what type of appointment will be issued.

If the value of the estate exceeds R125 000, the Master must appoint an executor. If the deceased left a valid will in which he or she nominated an executor, the Master will normally appoint the nominated person. Where, however, the deceased did not leave a valid will, the Administration of Estates Act determines how the Master must go about appointing an executor dative. The procedure is either to call for written nominations from all heirs, or to convene an estate meeting of all interested parties (heirs and creditors), for the purpose of nominating a suitable person for appointment as executor.

If the value of the estate is less than R125 000, the Master may dispense with the appointment of an executor and may appoint a Master's Representative. The Master refers to this type of appointment as a Section 18(3) appointment. It is a shortened

procedure with very little supervision and control by the Master after the appointment has been issued.

As far as the appointment of a **suitable executor** is concerned, the following should be noted:

- The Master must decide whether letters of executorship can be issued to a specific person or not. This applies to persons nominated by the testator in a valid will and also to persons nominated at estate meetings. In terms of the Administration of Estates Act, the Master may not appoint a person who is incapacitated from being an executor of the estate of the deceased, or one who has not complied with the provisions of the Act.
- Where a bank, trust company, auditor or an attorney has been nominated as executor, the Master will usually give effect to such nomination.
- It often happens that a next-of-kin or friend of the deceased is nominated as executor in a will, and furthermore that the testator exempts such nominated person from furnishing security to the Master for the proper fulfillment of his or her duties as executor. This nomination takes place without consideration of the fact that the nominated person has had no training in estates or does not possess the specialized knowledge required by an executor to fulfill his or her legal duties as executor. In these instances the Master will only be prepared to give effect to the nomination if the nominated executor is assisted by a suitable person or authorized institution that possesses the necessary expertise. If the nominated executor refuses to appoint an agent to assist him or her and insists on administering the estate alone, the Master will usually insist on security being lodged for the proper fulfillment of the executor's duties. Private individuals seldom find security with the result that the Master refuses to appoint the nominated person without the necessary security.

1.5 The estate administration process

The primary function of the executor or Master's Representative is to take control of the deceased's assets, to pay all creditors and administration costs, and then to transfer the balance of the estate to the heirs of the deceased. Where the deceased left a valid will, the heirs are usually determined in the will, failing which the heirs are determined in accordance with the rules of the Intestate Succession Act, 81 of 1987. The whole administration process, from appointment of the executor until the finalization of the estate, takes place under the supervision of the Master of the High Court. The administration of an estate comprises briefly of the following:

- As soon as an executor is appointed, he or she must place an advertisement in the Government Gazette and in a local newspaper circulating in the district where the deceased resided, calling on all creditors of the deceased to lodge their claims against the estate within 30 days as from the date of the advertisement - this advertisement is referred to as the section 29 advertisement.
- At the same time the executor must take steps to identify all the deceased's assets and to take control of such assets. The executor must have the assets valued.
- The executor must open a banking account in the name of the estate and must deposit all funds received by him or her into such account. Any payments made by the executor must be made out of the estate banking account.
- The executor must notify institutions with which the deceased had any dealings, such as banks, Pension Department, Insurance Companies, SARS (South African Revenue Services) etc. of the death of the deceased. In the case of SARS the executor must provide the estate number and any details required by SARS to determine the deceased's final tax liability to SARS.

- Should there not be sufficient cash in the estate to pay all the creditors and administration costs, then the executor must, after consultation with the heirs, sell sufficient assets to cover the cash shortfall. Should their heirs not want to sell any assets, they can undertake to pay the cash shortfall into the estate.
- Within six months after being appointed as executor, the executor must compile and lodge with the Master of the High Court an account of his or her administration known as a Liquidation and Distribution Account. This account reflects all the deceased's assets and liabilities and how the balance for distribution is to be distributed to the heirs. Any income and expenditure received after date of death up until the account is lodged with the Master is also accounted for in the account. The account must be examined by personnel of the Master to ensure that it is correct in all aspects.
- After the Master has examined and approved the account, it must be advertised to lie for inspection for 21 days at the Master's Office, and if the deceased resided in a place other than where there is a Master's Office, also at the Magistrate's Office in that area. During this time any interested person may inspect the account and if he or she has any objection to anything in the account he or she may lodge the objection with the Master of the High Court during the 21 days.
- If there are no objections to the account within the 21 days, or if objections have been lodged, then after the objections have been finalized, the executor must proceed to pay all creditors and heirs within two months. The executor must also ensure that any fixed property is transferred to the heirs.
- Once the executor has complied with all his or her functions and the estate has been finalized, he or she can apply to the Master for a formal discharge of his or her duties as executor.

If the above process takes place without any complications, it takes approximately nine months to finalise an estate. However, if there are complications, it can sometimes take years to finalise an estate.

INTESTATE SUCCESSION

2.1 Introduction

Intestate succession in South Africa is governed by the Intestate Succession Act 81 of 1987 that came into operation on 18 March 1988 and applies to persons dying intestate (in whole or in part) on or after that date.

The law of intestate succession determines the heirs to a deceased estate in the following circumstances:

- a) When the deceased has failed to determine how and to whom his or her property must be awarded by will or antenuptial contract; or
- b) Where it is impossible to carry out the wishes of the deceased because the beneficiaries are, for example, unable to inherit, or do not wish to inherit or are predeceased.

It is possible for a person to die completely intestate or only partly intestate. An example of the latter is where a testator specially bequeaths one portion of his estate in a valid will, but omits to deal with the rest of his or her assets. In this instance the portion that has been bequeathed by will, will devolve testate in terms of and subject to any conditions contained in the will, while the rest of the estate will devolve according to the rules of intestate succession.

Prior to the decision in *Bhe and Others v Magistrate Khayelitsha and Others*, 2005 (1) SA 580 (CC) the rules of intestate succession did not apply to black people who died intestate and were married by customary law. The *Bhe* decision has now changed this, and presently the estates of all persons, irrespective of race or culture, who die intestate, will be governed by the rules of intestate succession as set out in the Intestate Succession Act, 81 of 1987.

2.2 The rules of intestate succession

The distribution of an estate in terms of the Intestate Succession Act 81 of 1987 can be summarized into nine rules.

2.2.1 Rule 1: Spouse or spouses, but no descendants

If the deceased leaves a spouse or spouses, but no descendants - the spouse or spouses are the sole heirs. In the case where the deceased was a husband in more than one customary union, the surviving spouses will inherit the estate in equal shares.

Where spouses are married in community of property the estate must first be divided in half before the rules of intestate succession can be applied. The surviving spouse will receive half by virtue of the marriage and the other half will devolve according to the rules of intestate succession.

Rule 1 can be explained by the following examples:

Example A:

Where the deceased was a spouse in a monogamous marriage (only one spouse), was married in community of property, and left no descendants: Amount available for distribution: R400 000.

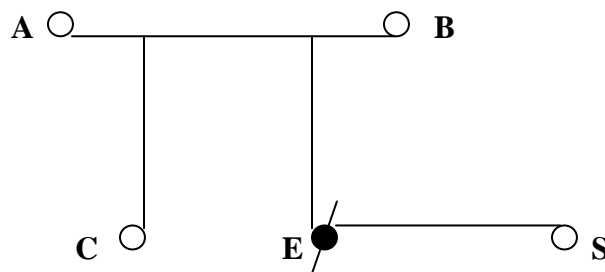

E = deceased: S = spouse: A = father: B = mother: C = brother

Solution:

The surviving spouse is the only intestate heir, irrespective of the value of the estate.

Because the spouses were married in community of property, the surviving spouse will receive one half of the balance for distribution (R200 000) by virtue of the marriage in community of property and the other half (R200 000) in terms of section 1(1)(a) of Intestate Succession Act 81 of 1987.

Example B:

Where the deceased was a spouse in a monogamous marriage (only one spouse), was married out of community of property, and left no descendants: Amount available for distribution: R400 000.

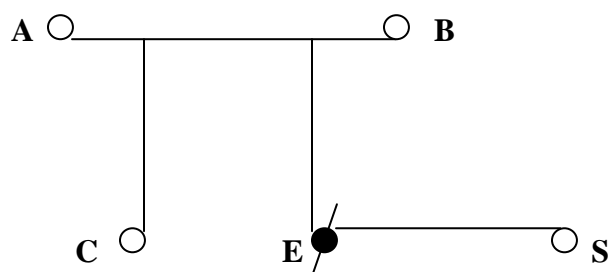

E = deceased: S = spouse: A = father: B = mother: C = brother

Solution:

The surviving spouse is the only intestate heir, irrespective of the value of the estate.

Because the deceased and surviving spouse were married out of community of property, the surviving spouse will inherit the whole balance for distribution in the amount of R400 000 in terms of section 1(1)(a) of the Intestate Succession Act 81 of 1987.

Example C:

Where the deceased was a spouse in a **polygamous marriage** (had more than one customary wife) and left no descendants: Polygamous marriages are usually out of community of property.

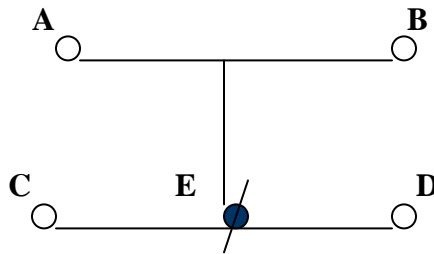

A & B = parents of the deceased; E = the deceased; C and D = customary marriage spouses of the deceased.

In terms of section 1(1)(a) of Act 81 of 1987, as amended by the Constitutional Court decision in **Bhe and Others v Magistrate Khayelitsha and Others**, the two spouses of the deceased (C and D) will inherit the estate in equal shares, to the exclusion of any other family members.

Note the following:

A question that needs to be answered is: “Who is a spouse for purposes of intestate succession?”

- a) As starting point it can be said that any party to a valid marriage in terms of the Marriage Act, 25 of 1961 (a civil marriage) is regarded as a spouse for purposes of intestate succession.

A civil marriage can be in or out of community of property. If the parties were married in South Africa, the default matrimonial property system applicable to their civil marriage is in community of property, unless they exclude community of property and community of profit and loss in an antenuptial contract.

- b) A party in a subsisting customary marriage which is recognised in terms of section 2 of the Recognition of Customary Marriages Act, 120 of 1998 is also a spouse for intestate succession purposes. These marriages include customary marriages which were validly concluded before the Act came into operation, and which still existed at the commencement of the Act (15 November 2000) as well as marriages concluded in terms of the provisions of the Act after the commencement of the Act.

As far as the matrimonial property system of customary marriages is concerned, one must distinguish between customary marriages concluded after the Recognition of Customary Marriages Act, and those concluded before the Act.

A Customary marriage concluded after the Recognition of Customary Act in which a spouse is not a partner in any other existing customary marriage, is, just as a civil marriage, in community of property, unless the parties entered into an antenuptial contract in which they excluded the community of property and community of profit and loss – Section 7(2) of the Recognition of Customary Marriages Act 120 of 1998 refers.

When it comes to customary marriages entered into before the commencement of the Act, one must once again distinguish between monogamous marriages and polygamous marriages.

In terms of section 7(1) of the Recognition of Customary Marriages Act, marriages entered into before the commencement of the Act continue to be governed by customary law. As customary law does not recognise either in or out of community of property, but rather subscribes to a family orientated property system, the view

has always been in the past that such marriages be regarded as out of community of property for estate purposes. However, in the Constitutional Court decision of *Gumede v President of the Republic of South Africa and Others*, Case No. CCT 50/08 (2008) ZACC 23, handed down on 8 December 2008, it was held that section 7(1) of the Recognition of Customary Marriages Act is inconsistent with the Constitution and invalid to the extent that its provisions relate to monogamous customary marriages. This means that monogamous customary marriages entered into before the commencement of the Act are now also deemed to be in community of property.

The Gumede decision did not however decide on polygamous marriages entered into before the commencement of the Act, and therefore such marriages are governed by customary law and deemed out of community of property, until the legislature or court decides otherwise.

Section 3(1) of the Reform of Customary Law of Succession and Regulation of Related Matters Act, 11 of 2009, which came into operation on 20 September 2010, has created a further group of women who qualify as spouses for intestate succession purposes. They are the seed-bearing woman in terms of Customary Law. Section 2(2)(b) and (c) of the Act describes these woman as follows:

“(b) a woman, other than the spouse of the deceased, with whom he had entered into a union in accordance with customary law for the purpose of providing children for his spouse’s house...;

(c) if the deceased was a woman who was married to another woman under customary law for the purpose of providing children for the deceased’s house..”

- c) Persons married in terms of Muslim and Hindu religious rites should be regarded as spouses for purposes of intestate succession and are entitled to inherit from their deceased partner in terms of the Intestate Succession Act, despite the fact that their “marriage” is not recognised as a valid marriage in terms of our current law. See

in this regard **Daniels v Campbell NO & Others** 2004 (5) SA 331 (CC) where the court recognised the woman in a monogamous Muslim marriage as a “spouse” for purposes of intestate succession and the Maintenance of Surviving Spouse Act, 27 of 1990. Also refer to **Khan v Khan** 2005 (2) SA 272 (T), where the court held that a partner in a polygamous marriage was entitled to maintenance in terms of the Maintenance Act 99 of 1998. In this case the court held that polygamous marriages were a type of family and had to be protected by family law

In a recent case on Muslim polygamous marriages (**Hassam v Jacobs N.O. & others** (2008) JOL 22098 (C)) the court found no justification for excluding the widows of polygamous Muslim marriages from the provisions of the Maintenance of the Surviving Spouses Act 27 of 1990 and the Intestate Succession Act 81 of 1987. The court held that the continued exclusion of the widows of polygamous Muslim marriages from the benefits of the Acts would be unfairly discriminatory against them and be in conflict with the provisions of section 9 of the Constitution.

Marriages in terms of Muslim and Hindu religious rites are generally regarded as being out of community of property.

- d) In **Gory v Kolver** CCT 28/06 the Constitutional Court ruled that partners in a permanent same-sex life partnership should be regarded as “spouses” for intestate succession purposes. The court in this matter held that it was generally accepted that lifelong same- sex relationships deserved the same protection as heterosexual marriages, and in so far as statutory provisions did not afford such relationships the same protection, (same-sex partners could not legally marry), the provisions in the Intestate Succession Act that excluded such partners as spouses were inconsistent with the Constitution. The subsequent enactment of the Civil Union Act 17 of 2006 which came into operation on 1 December 2006 has however limited the field of application of this decision, as same-sex couples who enter into a marriage or civil partnership in terms of the Civil Union Act now in any event enjoy all the rights of spouses in a civil marriage in terms of the Marriage Act 25 of 1961. To summarize

it means that persons who died before 1 December 2006, and were partners in a same-sex life partnership at the time of their death, should be regarded as “spouses” for purposes of intestate succession, while persons in same-sex relationships who died on or after 1 December 2006 should only be regarded as “spouses” if they had entered into a marriage or civil partnership in terms of the Civil Union Act. There are however writers who differ from this view, and feel that the protection given in the Gory decision still stands, notwithstanding the enactment of the Civil Union Act, 17 of 2006. For more information refer to the **SALJ, Vol 125 Part 2, pages 46 to 62 and pages 259 to 273.**

- e) In **Volks NO v Robinson and Others** 2005 (5) BCLR 446 (CC) the Constitutional Court had to decide whether a surviving partner in a heterosexual life partnership, where no marriage had been concluded between the partners, could institute a claim for maintenance against the estate of the other partner in terms of the Maintenance of Surviving Spouses Act 27 of 1990. The court held that such partner could not be regarded as a surviving “spouse” for purposes of the Act. The main majority judgment found that the purpose of the specific Act was to extend an invariable consequence of marriage beyond the death of one of the spouses. Whilst there was a reciprocal duty of support between married persons, there was no such legal duty upon unmarried persons. To extend the provisions of the Act to the estate of a deceased person who was not obliged during his lifetime to maintain his partner would amount to imposing a duty after death where none had existed during his or her lifetime.

The **Volks v Robinson** decision must be distinguished from the **Gory v Kolver** decision. Partners in a heterosexual life partnership can marry, but choose not to, and therefore it cannot be regarded as discriminatory to distinguish between spouses in a marriage and partners in a heterosexual life partnership, while in a same-sex lifelong partnership the partners could not legally marry before the commencement of the Civil Union Act 17 of 2006 and therefore their exclusion from the provisions

of the Intestate Succession Act and the Maintenance of Surviving Spouse Act was discriminatory and unconstitutional.

2.2.2 Rule 2: No spouse, but descendants

If the deceased does not leave a spouse but leaves descendants – the descendants inherit *per stirpes* and representation is allowed.

Example:

A & B = parents

X = deceased

C = predeceased spouse

E = predeceased child

D & F = children

J & K = grandchildren

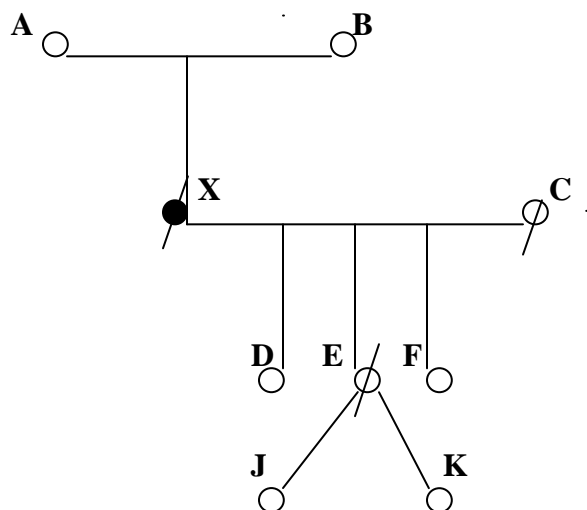

The deceased's children, D, E and F will inherit the estate in equal shares. Because E is predeceased, his or her descendants, J and K will represent him/her and inherit his or her share in equal shares.

Note the following:

All the deceased's children are entitled to inherit. It makes no difference whether they were born from a civil marriage, customary marriage, were adopted or born out of wedlock.

In terms of section 1(2) of the Intestate Succession Act illegitimacy does not affect the capacity of one blood relation to inherit intestate from another blood relation.

Section 1 of the Reform of Customary Law of Succession and Regulation of Related Matters Act, 11 of 2009, which came into operation on 20 September 2010, has created a further group of persons who qualify as descendants for intestate succession purposes where the deceased during his lifetime lived according to customary law. A descendant is defined in the Act as follows:

“a person who is not a descendant in terms of the Intestate Succession Act, but who, during the lifetime of the deceased person, was accepted by the deceased person in accordance with customary law as his or her own child;”

2.2.3 Rule 3: Spouse or spouses, and descendants

If the deceased leaves a spouse or spouses and descendants – the spouse or spouses inherit the greater of R125 000 per spouse or a child’s share, and the descendants will inherit the residue, if any, *per stirpes* and representation is allowed.

Example:

A, B = parents

C = brother

E = the deceased

S = surviving spouse

D = predeceased child

F, G = children

H, I = grandchildren

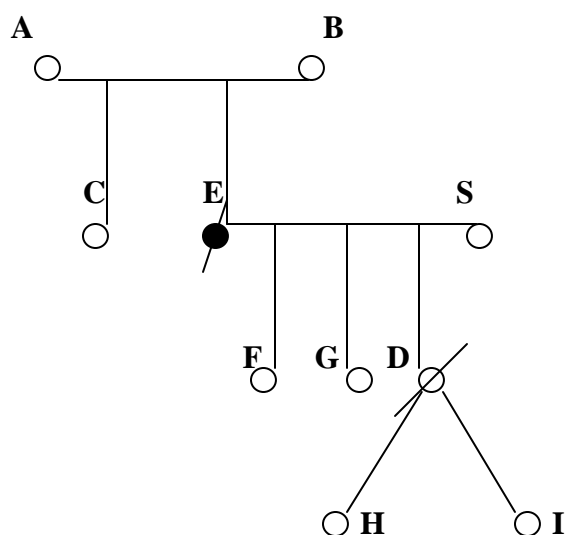

Note the following:

1. If the value of the estate is less than R125 000, the surviving spouse, in the above example, (S) will inherit the whole estate, to the exclusion of the children and other family members.
2. If the deceased was a husband in a polygamous marriage and is survived by more than one wife, and the value of the estate is less than R125 000 then the surviving spouses will share the balance for distribution equally between them, to the exclusion of the children and other family members.
3. If the balance for distribution in the estate is more than R125 000, the surviving spouse will inherit R125 000 or a child's share, whichever is the greater, and the balance will be divided among the descendants of the deceased *per stirpes* and representation is allowed. Applied to the above example, it would mean that F, G and D will inherit the balance. Because D is predeceased, his or her share will devolve in equal shares upon his or her descendants, H and I. If D did not leave any descendants, then his or her share will be divided between the other children of the deceased, namely F and G.
4. If the balance for distribution in the estate is more than R125 000 and the deceased is survived by more than one spouse (only applicable in the instance where the deceased was the husband in more than one customary marriage), then each spouse will be entitled to a child's share or R125 000 whichever is the greater, before any balance is divided among the descendants of the deceased.
5. Remember that if the spouses were married in community of property, the surviving spouse will receive one half by virtue of the marriage in community of property and one half in terms of section 1(1)(a) of Act 81 of 1987.
6. Also refer to the discussion of who is regarded as a spouse under rule 1 above.

7. Where a deceased dies partly testate and partly intestate, the amount which a surviving spouse receives in terms of the will is ignored in calculating the intestate amount to which the surviving spouse is entitled under Act 81 of 1987 – **In re MacGillivray’s Will** 1943 WLD 29 at 40.

2.2.4 Rule 4: No spouse or descendants, but both parents alive

If the deceased leaves no spouse or descendants but leaves both parents who are still alive – the parents will inherit in equal shares.

Example:

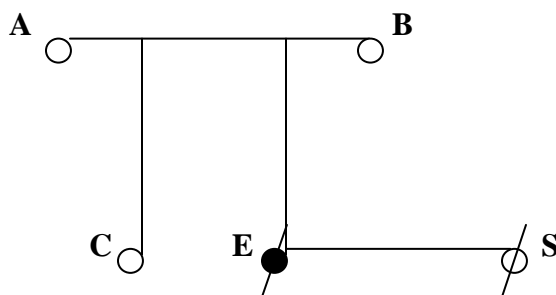

A & B = parents of the deceased; C = brother of the deceased; E = the deceased; S = predeceased spouse of the deceased.

In the above example, A and B, the parents of the deceased, will inherit the estate in equal shares, to the exclusion of the deceased’s other relatives.

Note that it makes no difference whether the deceased’s parents are married, divorced or never married.

For purposes of intestate succession, the parents of the deceased are his or her biological parents (unless the deceased was adopted by someone other than his or her biological

parents) and his or her adoptive parents. Note that if the deceased was adopted then his biological parents are deemed not to be his parents.

Stepparents and foster parents are not parents of the deceased for purposes of intestate succession.

2.2.5 Rule 5: No spouse or descendants, only one parent alive, deceased parent left descendants

If the deceased leaves no spouse and no descendants but leaves one parent, while the deceased parent left descendants – the surviving parent inherits one half, and the descendants of the deceased parent inherits the other half.

Example:

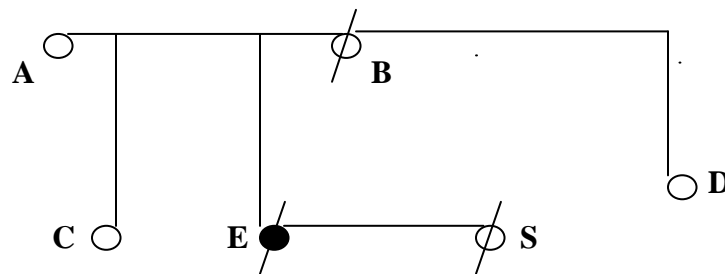

A = parent of the deceased; B = predeceased parent; C = brother of the deceased; D = half brother/sister; E = the deceased; S = predeceased spouse.

In this example, A the deceased's parent who is alive at his or her death will inherit one half of the balance for distribution, and the deceased's brother, C and half brother/sister D, will inherit the other half in equal shares. C and D inherit the half share that the deceased parent would have inherited had he/she been alive.

2.2.6 Rule 6: No spouse or descendants, one parent alive, deceased parent left no descendants

If the deceased leaves no spouse or descendants but leaves one surviving parent, while the deceased parent did not leave any other descendants – the surviving parent is the sole heir.

Example:

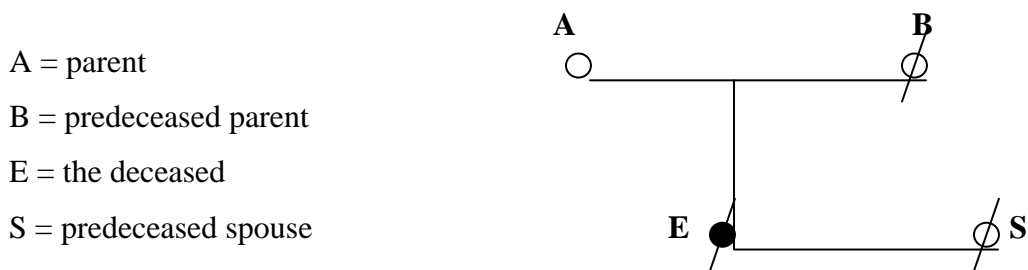

In this example A, the deceased's parent who is alive, is the sole heir.

2.2.7 Rule 7 spouse, descendants or parents, both parents left descendants

If the deceased does not leave a spouse or descendants or parents, while his parents both have left descendants – the descendants of the predeceased parents will inherit the half shares that would have been inherited by the respective parents.

Example:

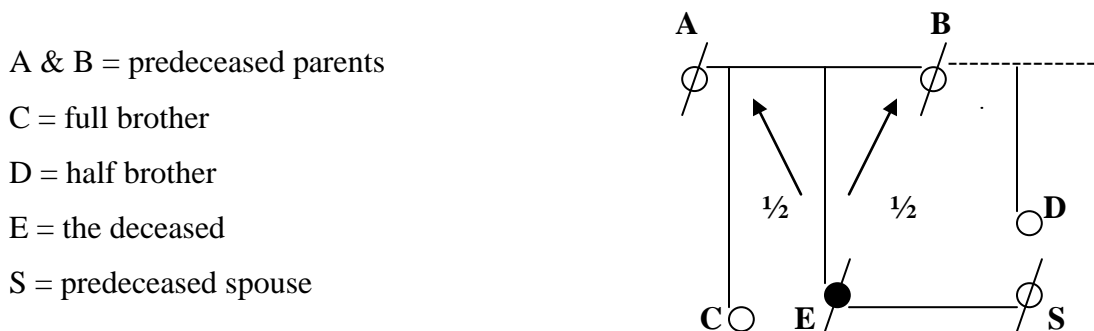

Because the deceased left no spouse, descendants or parents, the estate splits into two halves – a “mother” half and a “father” half. Each parent’s half share then devolves upon his descendants. In the above example A’s share will devolve upon C who is his or her only surviving child, while B’s share will devolve upon C and D in equal shares. C will thus inherit from A and B, while D only inherits from B.

2.2.8 Rule 8: No spouse, descendants or parents, only one parent left descendants

If the deceased does not leave a spouse, or descendants or parents, while only one of his predeceased parents has left descendants – the descendants of the parent who left descendants, are the sole heirs.

Example:

A, B = predeceased parents

D = half brother

E = the deceased

S = predeceased spouse

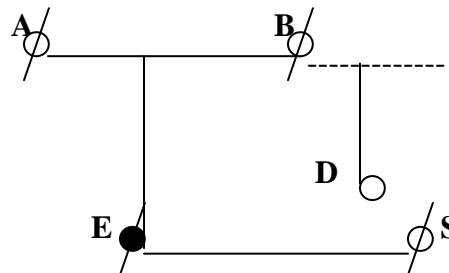

In the above example both parents are deceased and only one parent, namely B, has left a descendant. D, the half brother of the deceased will inherit the entire estate.

2.2.9 Rule 9: No spouse, descendants or parents, neither parents left descendants

If the deceased does not leave a spouse or descendants or parents or descendants of the parents – the nearest blood relation inherits.

Example:

C, D = predeceased grandparents

A, B = predeceased parents

E = the deceased

S = predeceased spouse

F = uncle

G = cousin

H = second cousin

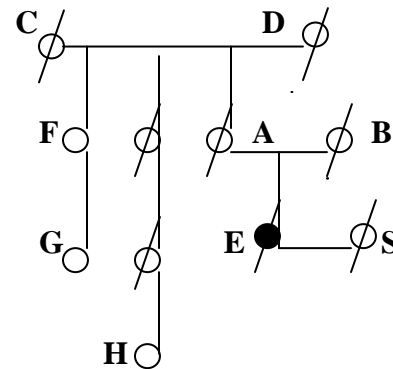

In the above example, F, the uncle of the deceased, is his nearest blood relation, being related to the deceased in the third degree, and will therefore inherit the whole balance for distribution. G is related to E in the fourth degree and H is related to E in the fifth degree. Both G and H will not inherit anything from E.

2.2.10 No intestate heirs

A person may die intestate without leaving any person capable of inheriting from him or her.

According to our common law, in such cases the State acquired the whole estate as *bona vacantia*. The matter is now regulated by sections 35(13) and 92 of the Administration of Estates Act 66 of 1965. The procedure is that where the intestate heirs are unknown or where there are no intestate heirs, the executor converts the intestate estate into cash and after payment of the deceased's debts, pays the residue into the Guardian's Fund. If nobody is able to prove that they have a claim to the money as an intestate heir of the deceased, then after 30 years have elapsed after payment of the funds into the Guardian's Fund, the money will accrue to the state.

The Master of the High Court publishes the particulars concerning money in intestate estates which have been paid into the Guardian's Fund from time to time in extraordinary issues of the Government Gazette so that interested persons may claim it as intestate heirs of the deceased persons concerned.

TESTATE SUCCESSION: WILLS

3.1 What is a will?

In its simplest form, a will, also known as a testament, is a document in which a person sets out what must happen to their estate when they die. A person can also nominate the person or persons, known as executors, who should administer their estate on their death.

The person who makes a will is known as the testator (male) or testatrix (female).

A person's estate consists of all their assets (belongings, property) and liabilities (debts) which they had as at date of death.

To administer an estate means to collect or take control of all the assets of the deceased, to pay the debts which the deceased left at date of death, and then to pay the balance left for distribution to the rightful heirs of the deceased as determined in the will, or if you do not have a will, to the heirs as determined in terms of the rules of intestate succession.

Every person can make his or her own separate will, whether married or unmarried, in which he or she disposes of his or her own separate assets, or in the case of someone married in community of property, disposes of his or her half share of the joint estate.

It is also possible for two or more persons, for example spouses, to make a joint will, in which they dispose of their separate estates.

A will can be a very straight-forward document in which the testator merely names the person who must administer his or her estate and sets out who must inherit his or her property when he or she dies, or it can be a very complicated document which contains usufructs, *fideicommissums*, trusts and other conditions.

If a will is very straight-forward there is nothing that prevents the testator or testatrix from compiling his or her own will, provided that it complies with the requirements of the Wills Act. The requirements are discussed below. In fact, fill-in wills can be purchased at selective book-stores. However, wills that are even slightly complicated should preferably be drawn up by an expert such as an attorney or trust company (e.g. Absa Trust, Standard Trust, First National Trust, etc.).

Once a will has been made, it can be revoked (withdrawn, cancelled) or amended by the person who made it, at any time before the death of such person.

3.2 Why should a person make a will?

The benefits of having a valid will are primarily twofold. First of all by making a will, the person who does so, exercises his or her right to decide who should inherit his or her property when he/she dies. Should a person fail to leave a valid will, then his or her property (after all estate debts have been paid) will be awarded to his or her heirs as determined by an Act of Parliament, namely the Intestate Succession Act. Although a person's intestate heirs are usually his or her next of kin, such heirs are not necessarily the people whom the deceased would have wanted to inherit his or her assets.

In the past, many Black persons did not make wills in view of the fact that their culture determined who would inherit their estate on their death. Generally speaking, Black women could not own property, and in most Black cultures it was the eldest male child of the deceased man, failing which, his father or eldest brother who inherited his estate.

An important Constitutional Court decision, *Bhe and Others v the Magistrate Khayelitsha and Others*, handed down on 15 October 2004, drastically changed the customary law of succession. In terms of that decision, the estates of all persons who die without a valid will, irrespective of race, gender or culture, must now be administered in terms of the Intestate Succession Act.

The second benefit of making a valid will, is that the person who does so, can stipulate who should be appointed to administer his or her estate. The person who administers the estate is called an executor. Should a person die without leaving a valid will in which he/she says who must be the executor, then the Master of the High Court, after discussion with the heirs and next-of-kin of the deceased, will appoint a suitable person to administer the estate.

3.3. Who can make a will?

Any person over the age of 16 can make a will, provided he or she is not mentally ill, and is also capable of understanding the consequences of his or her actions.

3.4. Aspects to be considered before drafting a will

A will is a very important document and the Wills Act, 7 of 1953 (as amended) prescribes certain formalities for it to be valid. If a document which is intended to be a will does not comply with the formality requirements, the Master of the High Court will be compelled to reject the will, in which case the deceased's estate will devolve in terms of the Intestate Succession Act. If a will is rejected by the Master on the basis that it does not comply with all the formalities, any interested party can apply to the High Court for an order directing the Master to accept the will. However, an application to the High Court is very expensive and should be avoided at all costs.

Assistance in the drafting of an elementary will can be obtained from attorneys, chartered accountants, boards of executors, banks, insurance companies, trust companies, and various individuals who have the necessary background and qualifications to draft wills. The costs involved in the drafting of an elementary will are usually minimal and some of the institutions will draft a will free of charge provided the institution is nominated as executor in the estate. Should comprehensive estate planning be required (and this includes the drafting of a will) it is recommended that the assistance of a professional

estate planner be sought. The professional estate planner will usually charge a fee for his services, but the advantages of such services usually justify the costs incurred.

If a person has drafted any previous wills, or had such documents drafted, it is important to revoke previously drafted wills in a later will, otherwise all the wills will be deemed valid if they comply with the formality requirements and will have to be read together.

Before a person drafts a will or requests someone to draft a will on his or her behalf, he or she must first think carefully regarding the provisions of the proposed will. Aspects that need to be considered include the following:

- ***The executor:***
 - Who should be the executor?
 - Do you want to nominate more than one person as executor?
 - Do you want to make provision for a substitute executor should the person you nominate not be able to, or not want to take the appointment?
 - Must the executor provide security to the Master for the proper fulfillment of his or her duties?

- ***What is your marital status – are you single or married?***
 - If you are married, how are you married. Are you married in terms of Civil Law, Customary Law, the Civil Union Act or is it a religious marriage (e.g. Moslem or Hindu marriage).
 - Are you married in or out of community of property, with or without the accrual system?
 - If you are married in community of property, remember that your spouse owns half of the joint estate, and you can therefore only make a will regarding your half share of the joint estate.

- *Who do you want to appoint as heirs?*

- *The circumstances of your heirs-*
 - Are any of your heirs minors?
 - ❖ If you are the sole guardian of the minor, must provision be made for the appointment of a tutor or a guardian?
 - ❖ To whom must the minor's inheritance be paid for safekeeping until he or she becomes a major? Options include the following: The Master's Guardian's Fund; payment to a natural guardian of the minor; the creation of a trust for the minor.

 - Do any of your heirs need special protection?
 - ❖ Heirs who are legally incapable of managing their own affairs, e.g. someone who suffers from a severe or profound intellectual disability.
 - ❖ Heirs who cannot work with money – spendthrifts.
 - ❖ What should happen if any one of your heirs is insolvent at the time of your death?

- *What type of bequest do you want to make (e.g. a legacy, usufruct, fideicommissum, creation of a trust)?*

3.5. Formality requirements to make a will

The formality requirements for a will are set out in section 2(1) of the Wills Act, Act No 7 of 1953.

All wills must be in **writing**. A will can be written by hand, typed or be in the form of a printed document (such as the fill-in documents purchased from selective book stores).

In terms of the Wills Act it is possible for a testator/testatrix to sign his or will personally, or to ask someone to sign the will on his or her behalf. It is recommended that if it is at all possible, a testator or testatrix should sign his or her will personally.

3.5.1 Formalities where the testator/testatrix personally signs a will

All wills must be **signed** by the testator or testatrix **at the end** thereof. “Signed” in the case of the testator or testatrix means either a full signature, initials or a mark e.g. thumb print or an “X”. It is recommended that a testator or testatrix, if at all possible, avoids using a mark to sign his or her will, because if they use a mark, then additional formality requirements are set for the will to be valid – see. 3.5.2 below. The best way to sign a will is to use a full signature. “At the end of the will”, means as close as possible to the end of the wording of the will, and not the end of the page on which the will ends. This is for security purposes, to avoid any person besides the testator/testatrix from adding information to the will after it has been signed by him/her.

If the will consists of more than one page, the **testator or testatrix must sign all the pages of the will**. Except for the last page of the will, which must be signed at the end thereof, all the other pages can be signed anywhere on the page. In practice all pages of the will are usually signed at the end of the page.

The will must be signed **in the presence of at least two competent witnesses**, who are present at the same time. A competent witness is any person over the age of 14 years, who is not mentally ill, and who, at the time at which they witness the will, are regarded as competent to give evidence in a court of law.

As evidence of the fact that the testator or testatrix signed the will in their presence, the **witnesses each must sign the will** in the presence of the testator or testatrix and each other. Although the testator or testatrix must sign all the pages of the will in the presence of the witnesses, the witnesses only need to sign the last page of the will. Once again, in practice the witnesses usually sign all the pages of the will.

It should be noted that the person who signs the will as a witness need not know what the content of the will is. They must however be aware of the fact that they are witnessing a will.

A person who, in terms of the will is to receive any benefit from the estate, or his or her spouse, should not be a witness to the will, as this will, with certain exceptions, disqualify them from receiving the benefit in terms of the will. A benefit in this instance includes the nomination as an heir, executor, trustee or guardian of any minor children of the deceased. It is recommended that witnesses be totally impartial persons, e.g. neighbours, friends, etc. provided they are not beneficiaries in terms of the will.

3.5.2 Formalities where the testator/testatrix signs a will by means of a mark or requests someone to sign the will on his or her behalf.

Where a testator/testatrix signs a will by means of a mark or requests someone to sign the will on his or her behalf in his or her presence, then the signing and witnessing of the will must take place before a Commissioner of Oaths. Examples of Commissioners of Oaths are police officers, post masters, bank managers, attorneys, etc.

Once the will has been signed and witnessed before the Commissioner of Oaths, the latter must add a certificate to the will in which he or she certifies that he/she has satisfied him/herself as to the identity of the testator/testatrix, and that the document which has been signed and witnessed is in fact the will of the testator/testatrix.

The Commissioner of Oaths must sign the certificate and also every other page of the will, anywhere on the page.

The certificate by the Commissioner of Oaths must be added to the will as soon as possible after the will has been signed by the testator or person who signs the will on behalf of the testator and the witnesses.

3.6. Requirements for the amendment of a will

A will can be amended by the testator/testatrix at the time of the initial signing thereof, or at any time thereafter. Amendment means a deletion, addition, alteration or any writing between the lines of the text of the document.

Any amendments to a will must be identified by the signature of the testator/testatrix, or the person who signs the amendment on behalf of and in the presence of the testator/testatrix, and at least two competent witnesses, all present at the same time.

In order to identify the amendments, it means that the signatures must be made as close as possible to the specific amendments.

What has been said above in 3.5.1 with regard to witnesses of the will, also applies to witnesses to any amendment of the will.

As with the execution of the will, any amendments where the testator/testatrix signs by means of a mark, or requests someone else to sign the amendments on his or her behalf and in his presence, must be made before a Commissioner of Oaths. The Commissioner of Oaths must also certify on the will that he/she has satisfied him/herself as to the identity of the testator and that the amendments have been made by or at the request of the testator. The Commissioner of Oaths must sign his or her certificate.

It should be noted that the witnesses who witness and sign amendments to a will made by the testator need not be the same witnesses as those who initially witnessed the will.

3.7. What happens if a will does not comply with all the above formalities?

If a will does not comply with all the formalities set out in 3.5 above, the document will be rejected by the Master of the High Court. The deceased's estate will then have to be distributed in terms of the rules of intestate succession.

It is, however possible for any person having an interest in the estate, to approach the High Court for an order directing the Master of the High Court to accept the document as the valid will of the deceased, even if it does not comply with all the formalities. The Court will only grant such an order if it is satisfied that the document drafted or signed by the person, who has since died, was intended to be his or her will.

As court applications are costly and also delay the administration of the estate, it is suggested that testators make sure that their wills comply with all the necessary requirements.

3.8. Effect of divorce or annulment of marriage on a will

Section 2B of the Wills Act provides that:

“If any person dies within three months after his marriage was dissolved by a divorce or annulment by a competent court, and that person executed a will before the date of such dissolution, that will shall be implemented in the same manner as it would have been implemented if his previous spouse had died before the date of the dissolution concerned, unless it appears from the will that the testator intended to benefit his previous spouse notwithstanding the dissolution of his marriage.”

Note that the provision will not apply if it appears from the will that the testator intended to benefit his previous spouse, notwithstanding the dissolution of the marriage.

The provision can be illustrated as follows:

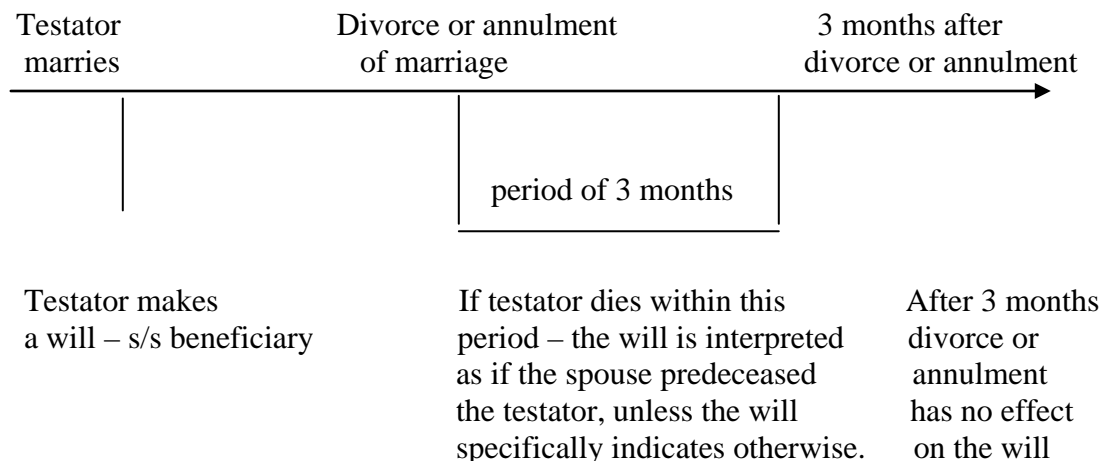

3.9. Safekeeping of wills

Wills should be kept in a safe place where they can easily be found when the testator or testatrix dies. Wills do not have to be stored at attorney's offices or at trust companies.

If a testator/testatrix decides to keep his or her will in a safe place him/herself, it is advisable that they inform a reliable person where the will can be found should they pass away.

3.10. Registration of a will on the death of the testator/testatrix

When a testator or testatrix dies, his or her estate must be reported to the Master of the High Court who has jurisdiction, within 14 days after death.

Although the Service Points of the Master situated at Magistrate's Offices have jurisdiction in certain estates, they do not have jurisdiction in estates where the deceased died, leaving a will.

The estate of a person who died, leaving a will, whether it be valid or not, must be reported to the Master of the High Court in whose area the person resided before death. At present there are 14 Masters' Offices, situated in Pretoria, Johannesburg, Mafikeng, Polokwane, Thohoyandou, Cape Town, Grahamstown, Port Elizabeth, Bhisho, Mthatha, Pietermaritzburg, Durban, Bloemfontein and Kimberley.

After the death of the testator/testatrix, all wills, whether they are valid or not, and irrespective of the number of wills, must be lodged with the Master of the High Court for registration and acceptance or rejection, together with the other documents required to report the estate.

After the estate has been reported to the Master of the High Court, the Master will appoint the executor who must then administer the estate.

Any person who steals or willfully destroys, conceals, falsifies or damages any document purporting to be a will, is guilty of an offence in terms of section 102 of the Administration of Estates Act, and if charged and found guilty of such an offence, is liable to a fine or to imprisonment for a period not exceeding seven years.

NB: This summary must not be seen as a comprehensive note on succession, intestate succession and wills.

Margaret Meyer
Masters' Training: Justice College
March 2011

Usual order of clauses

There is no specific order prescribed by law for a will, but the usual order for the various clauses can be as follows:

1. Declaring testamentary intent;
2. Revocation of previous wills, codicils or testamentary writings;
3. Nomination of executors;
4. Legacies;
5. Residue heir(s); and
6. Paragraph indication where (place) and date on which the will is being signed (Testimonium and attestation clause).

See next page for examples of wills:

WILL

(Will of one person – whether married or unmarried)

I, the undersigned, MOSES MOSELANA (Identity Number: 541125 0010 123) of 123 Florida Street, Cape Town, hereby declare this to be my last will and testament.

- 1 I hereby revoke all previous wills, codicils and testamentary dispositions made by me.
- 2 I nominate XYZ Trust to be the Executor of my estate, and exempt them from furnishing security to the Master of the High Court.
- 3 I bequeath my whole estate to my wife GLORIA MOSELANA.

Signed in the presence of the undersigned witnesses all of us being present simultaneously in CAPE TOWN on 2 June 2010.

TESTATOR

WITNESSES:

1 _____

2 _____

MUTUAL WILL

We, the undersigned, MAVIS JANTJIES (ID: 670427 0010 234) and JOHNNY JANTJIES (ID: 640629 098 345) residing at 123 Merry Road, JOHANNESBURG, married in/out of community of property, hereby declare this to be our last Will.

- 1 We hereby revoke all previous Wills and Testaments made by us either singly or jointly.
- 2 We nominate the survivor of us to be the executor of the estate of the first dying of us.
- 3 The nominated executor should be exempt from furnishing security to the Master of the High Court for the fulfillment of his/her duties as such.
- 4 Our car is bequeathed to our eldest son PIET JANTJIES (ID 900813 0789 456).
- 5 The residue of the estate of the first dying is bequeathed to the survivor of us.

Signed in the presence of the undersigned witnesses all of us being present simultaneously in JOHANNESBURG on 2 June 2010.

TESTATOR

TESTATRIX

WITNESSES:

1 _____

2 _____

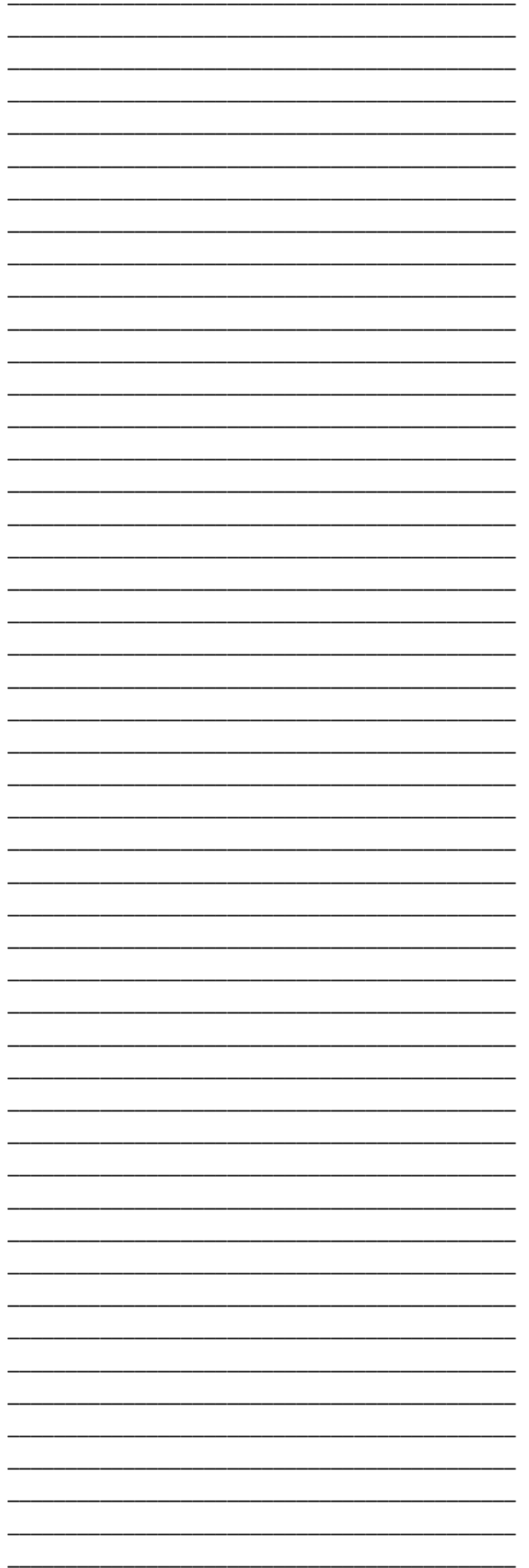
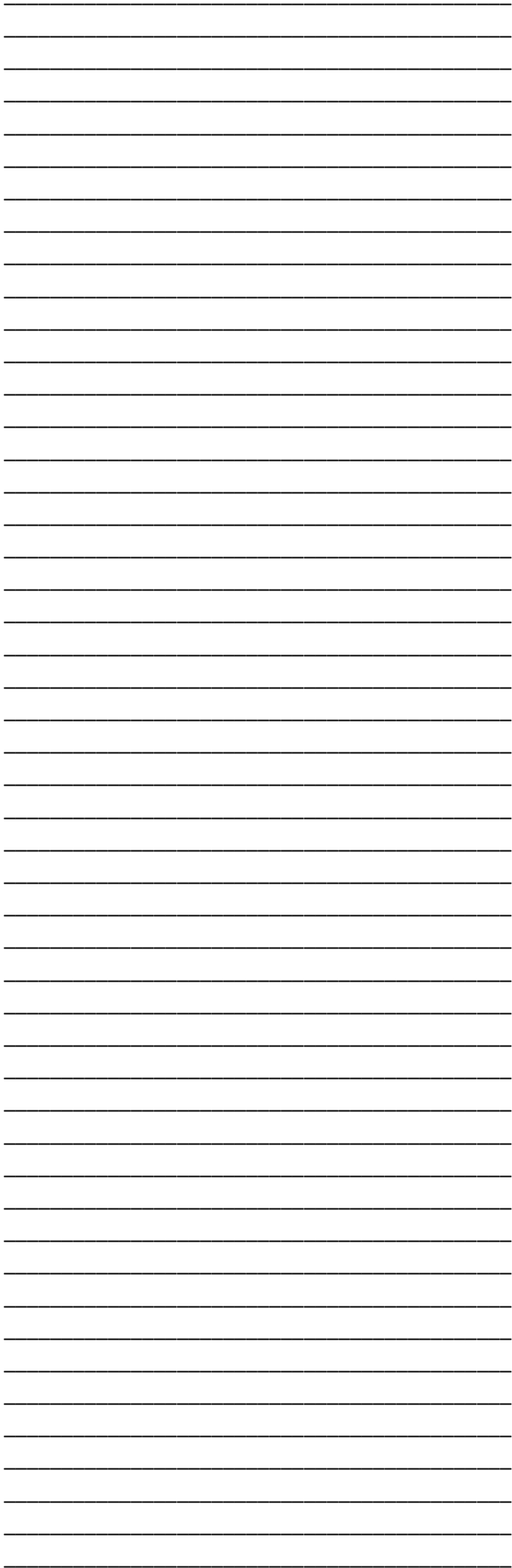

**DEPARTMENT: JUSTICE AND CONSTITUTIONAL DEVELOPMENT
REPUBLIC OF SOUTH AFRICA**

JUSTICE COLLEGE, Private Bag X 659 PRETORIA 0001 – Tel: (012) 481 2892 – Fax: (012) 481 2746
Building 10, UNISA Sunnyside Campus, Cnr Walker & Joubert Streets, SUNNYSIDE 0002



access to justice for all